



# Practical Science and Technology Made Fun

Great Value

Educational Kit



Structures  
Mechanisms  
Electronics  
Robots  
Problem Solving  
and  
Inventing  
for All

Design can be adapted  
as you want

Alternative ideas  
to use it for

# CleverBot The Versatile Robot

This CleverBot can be used for all types of robots designs. A few examples are shown. The robot is steered via the supplied ready to use manual controller. Learn about wiring up the control system, drive mechanism, structures. Use top supplied or design your own. More ideas on the Kre8 website.



Size 200mm

Controller used to steer left, right, forward, backwards and stop

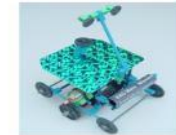

Space theme



Bomb disposal  
(with video cam)



Vehicle

Full Instructions



Graphic EduMedia  
Meeting your Every Educational Need

Probably the most CREATIVE and VERSATILE Making System Designed for Education

Cleverbot



4 x Blue clip connector

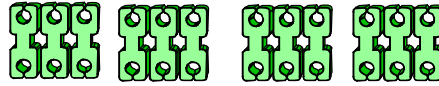

4 x Multiblocks (green)

**IMPORTANT - Keep TWO uncut**

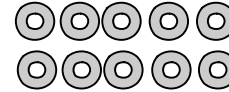

10 x steel washers

80mm long  
5mm  
snap  
rod

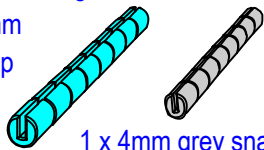

1 x 4mm grey snap

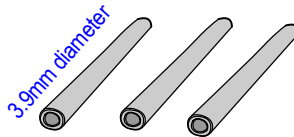

3 x grey rod

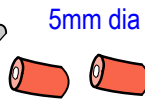

2 x dayglow tube

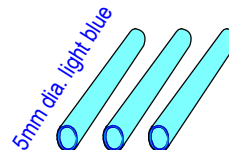

3 x 200mm long tubes

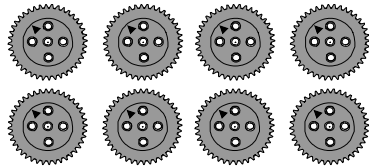
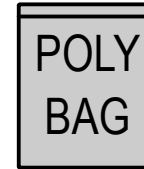

8 x 40mm dia. wheels



1 metre x ribbon cable  
(if using IQ2 controller only some is needed)

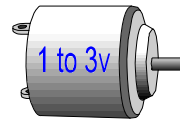

2 x small motors, 1 to 4.5 volts

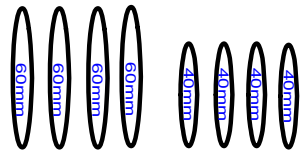
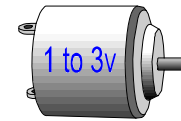

4 x 60mm and 4 x 40mm  
long rubber elastic bands

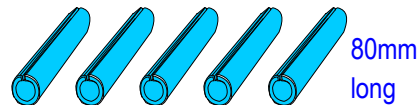

5 x 5mm dia. x Blue slit rods

**Abrasive paper**

Choice

A5 Laminate sheet  
and TOP  
printout

OR  
we can  
offer alternative  
holographic card top



2 x blue collars

**Leaflet insert**



Flag piece  
0.5mm thick  
plastic sheet  
(any colour)

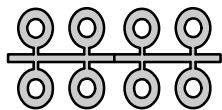

8 x 4mm grey collars

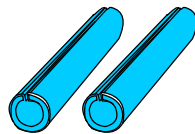

2 x 5mm diameter blue slit rods

## VERSIONS You also need the following:-

(A) Kre8 CleverBot with no controller - add your own

(B) Kre8 CleverBot with switch box controller

- 1) two switch boxes
- 2) grey tube
- 3) instructions



(C) Kre8 CleverBot with Manual controller

- 1) manual controller
- 2) instructions

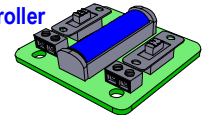

(D) Kre8 CleverBot with IQ controller

- 1) IQ controller, 2) 6Volt battery holder 3) 2x 10hm resistors

## Tools

### Snips

Use to cut Kre8 connector hinges, plastic sheet, light blue tubing (the serrated blades are better than smooth blades).



### Emery Cloth

Assembly is easier if you use fine 'emery cloth' or other 'abrasive paper' to round and smooth the slit rod or blue tube ends.

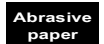

### Pencil and Rule

Use to mark lengths of blue tube or slit rods before cutting. Can also be used on plastic sheet before shapes are cut out. (FREE rule at bottom of page)



4mm dia. Drill Just in case the pulley wheel is too tight.

### DRILL SAFETY

Keep hands away from sharp edge when drilling



OTHER - Glue stick, clear tape paper punch and small screwdriver for the manual controller  
FOR IQ2 version SOLDERING IRON

# 3

# Kre8® CleverBot - Making 1



Tip - Visit [www.kre8.com](http://www.kre8.com) and click on the 'Movie' and 'Video' buttons

## To Make

Follow the 'step by step' instructions provided and adapt as you want.

## NOTES

- (1) Only cut the connectors when needed.
- (2) Use a ruler for measuring (bottom of page)
- (3) For easier assembly - smooth and round the rod ends with abrasive paper then push and twist the rods into the connectors.

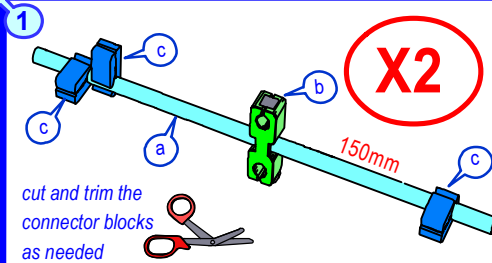

cut and trim the connector blocks as needed

Cut a light blue tube (a) 150mm long. Slide one green connector (b) to the centre then add three single blue connectors (c) as shown.

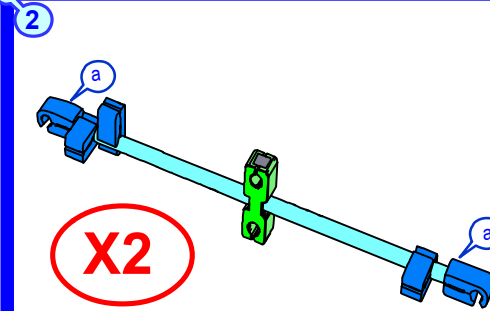

Add two blue connectors to the end (a) of the parts made in step one.

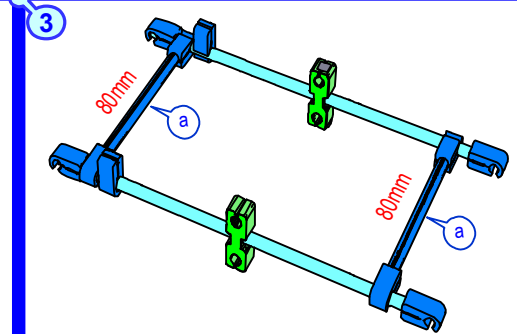

Link the two sides together using 80mm long slit rods (a).

## 4 Adding the PULLEY WHEELS

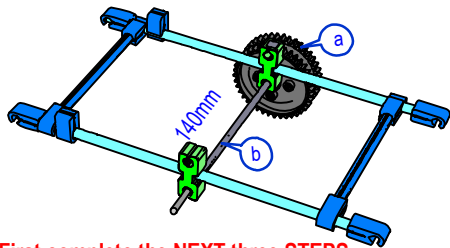

First complete the NEXT three STEPS then slide the two 'pulley wheels' (a) onto a 140mm long grey axle tube (b).

## 5 Making PULLEY WHEELS

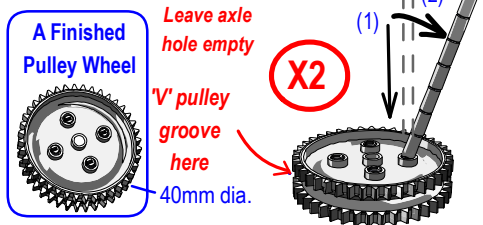

Leave axle hole empty  
"V" pulley groove here  
40mm dia.

Make by placing two wheels face to face, then join by:  
(1) pushing the 4mm snap rod into the outer holes.  
(2) snap rods off 1cm snap length by bending over.

## 5 Important

Check the pulley wheels 'spin' on the axle if not redrill axle hole 4mm.

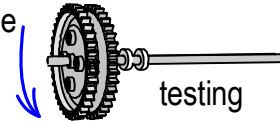

**SAFETY** If the axle hole needs enlarging, redrill onto a block of old wood NOT into your hand.

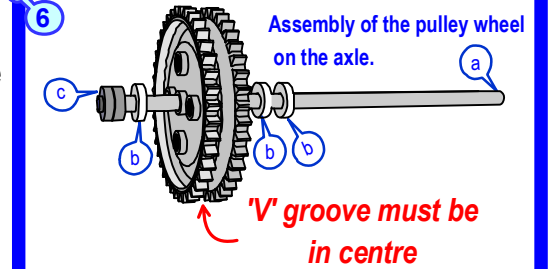

Assembly of the pulley wheel on the axle.  
"V" groove must be in centre  
This drawing shows how to assemble the pulley wheels onto the 3.9mm light grey axle (a) adding 3 metal washers (b) and 2 grey collars (c).

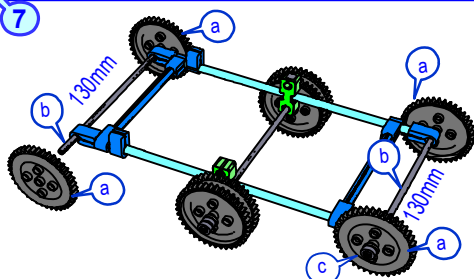

Add the four 40mm corner wheels (a) on the two 140mm long grey axle tubes as shown (b) then hold them on with grey collars (c)

## 8 Start Motor Holder Making

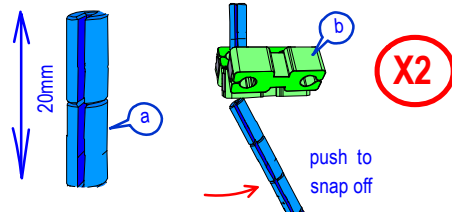

First snap off 20mm long piece (a) of 5mm dia. blue snap rod - it can be snapped off as shown by holding in a 'triple multiblock green connector' (b).

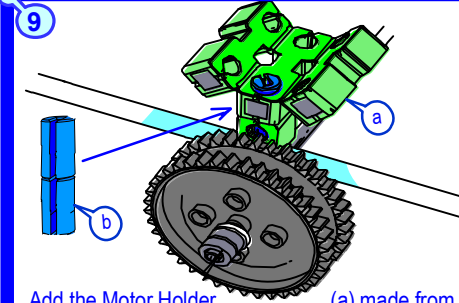

Add the Motor Holder (a) made from a triple multiblock to the body using the 20mm long piece of rod (b) to join them together.

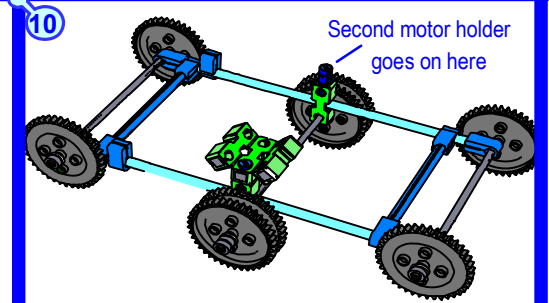

Add the second motor holder on the other side. continued .....

# 4

## Kre8® CleverBot - Making 2

Tip - Visit [www.kre8.com](http://www.kre8.com) and click on the 'Movie' and 'Video' buttons

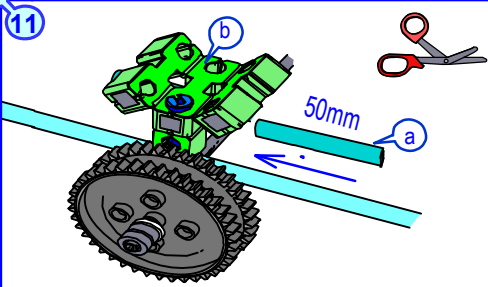
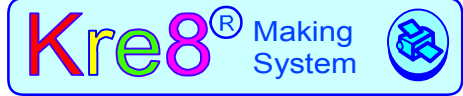

Push the 50mm light blue tube piece (a) through the centre hole of the middle green connector (b). Repeat for both left and right motor holders.

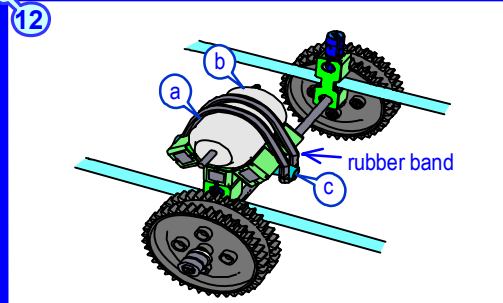

Loop a short 'rubber band'(a) over the motor(b) using the light blue tube(c) to hook over.

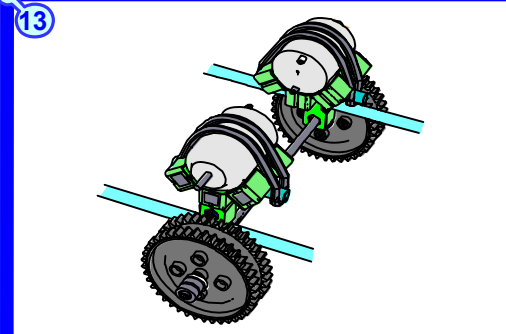

Add the second motor and motor mounting - Note - the motor spindles faces outwards.

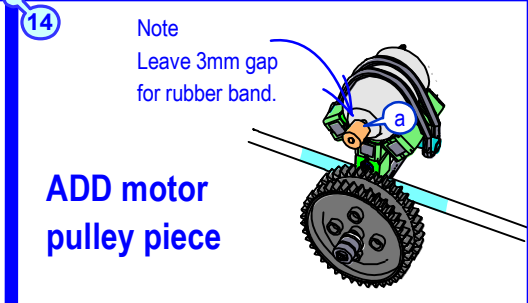

Note Leave 3mm gap for rubber band.  
**ADD motor pulley piece**  
Cut a short length, about 5mm long(a), off the end of the orange tube provided then push it onto the end of the motor spindle as shown.

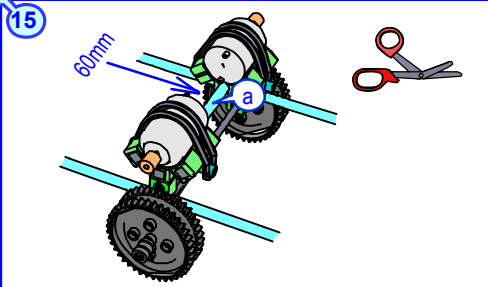

Cut then add a light blue cross piece 60mm long(a) in the bottom holes of the green connectors.

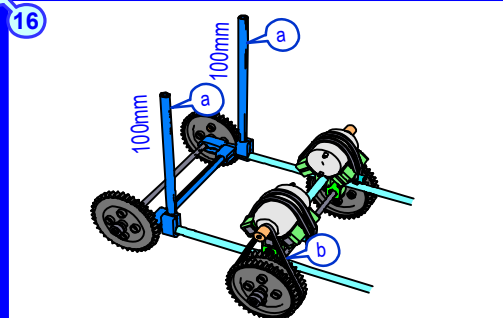

(1) Add two vertical 100mm long slit rods (a)  
(2) Add the drive belts (b) using the long rubber bands.

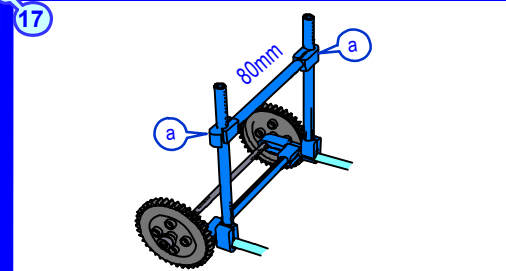

Link the two upright pieces (a) just added with a 80mm long rod and blue clip connectors (a) as shown.

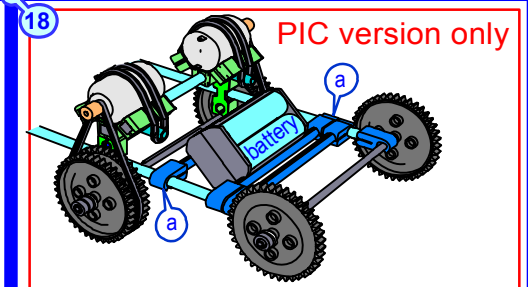

**PIC version only**  
If you want to add a small PIC controller you will need to make a holder for the battery- This can be done by adding extra support pieces (a) as shown.

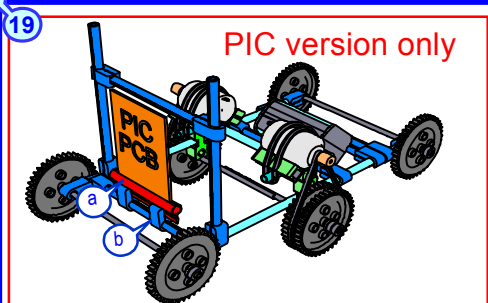

**PIC version only**  
The PIC controllers can be held in place using a red converter piece (a) held in place with two blue connectors (b) as shown.

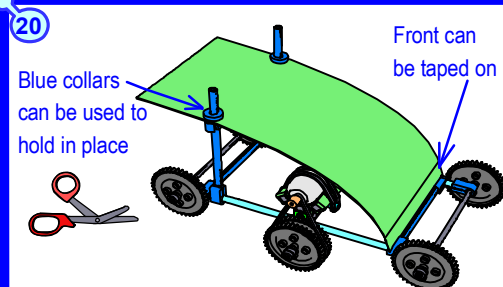

A simple top can be added by fixing it at the front and at the back as shown. Holes can be punched in the card top using a paper punch.

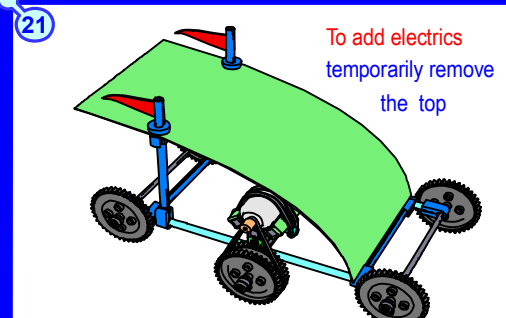

Extra parts can now be added to your own design such as flags etc.

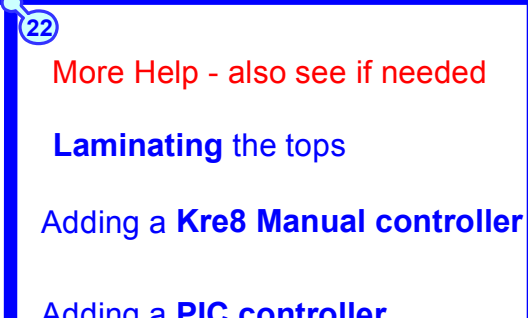

**More Help - also see if needed**  
**Laminating the tops**  
**Adding a Kre8 Manual controller**  
**Adding a PIC controller**