

Visit [www.kre8.com](http://www.kre8.com) for movies, zoomable pages and other support

## Contents

- P1 Introduction
- P 2 Parts List
- P 3 Making help photos
- P 4 Making help to page 9
- P 10 Top printout
- P 11 Wiring help
- P 12 Assembly movie



Time to make  
3 - 4 hours

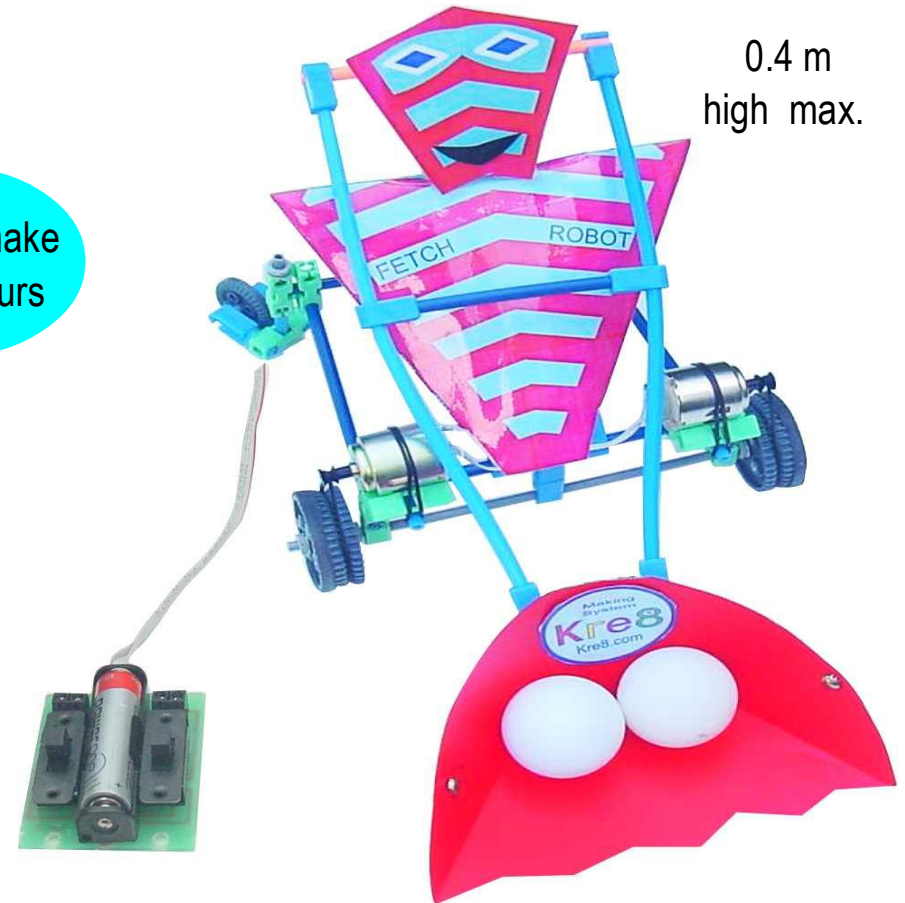

**Making skills** - Assembly and construction skills including wiring up the three motors.

**Designing** - You can design your own top or use the given design as shown (also printable on website)

**Control, Electrics and Mechanisms** - Learn how to connect up and control the electric motors. Assemble the mechanism with speed reduction pulley.

This fun steerable rescue type robot can collect (or rescue) items such as ping pong balls. The geared motor can lift the lifting arm up over the robots 'head'. Steer it using the the ready made hand controller to make it move forward, move backward and turn on the spot. NOTE - The geared down motor controller is supplied ready made (or can be supplied as parts). Just requires a screwdriver to connect up.

# 2

# Kre8® Rescue Robot - Parts List

**Trim all sharp edges after cutting**



6 x clip connectors - blue

Note  
two pairs needed  
(Don't cut all up)

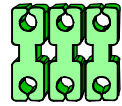

7 x Multiblocks (green)

Note  
two triples needed  
(Don't cut all up)

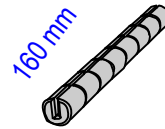

2 x 4mm dia. snap rods grey



5 x 5mm slit rod



1 x 5mm slit rod

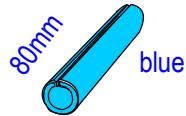

1 x 5mm slit rod

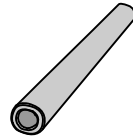

1 x 4mm grey tube

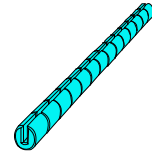

1 x 5mm snap rod

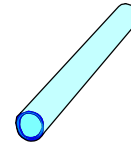

3 x 5mm light blue tube

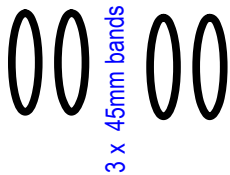

3 x 45mm bands

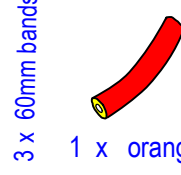

3 x 60mm bands



1 x orange tube

Abrasive paper

plastic sheet A5

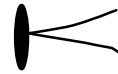

4 x split pins



Bag

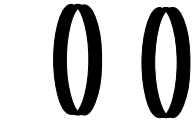

2 x wide rubber bands



6 x bearing



6 x grey collars

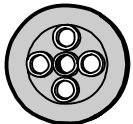

2 x 70 dia wheel grey

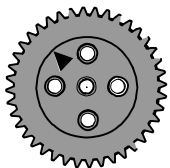

6 x 40 dia wheel grey



8 x washers 4mm ID

## Electrics

2 - motor pulleys

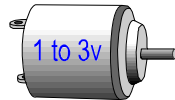

2 x electric motors

2 - Manual controllers

1 x Geared down motor

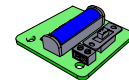
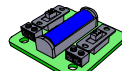

2 x 19mm s/ tap



1 x 6 way ribbon cable

## For Easy Assembly

The rods are easier to insert into the connectors if twisted as they are pushed into place.

Younger students should 'round off' and smooth the tube and rod ends using the abrasive paper.

## Tools



### Snips

Use to cut Kre8 connector hinges, plastic sheet, light blue tubing etc

**Scissors** for cutting out the decoration

### Emery Cloth

Use fine 'emery cloth' or other 'abrasive paper' to round and smooth the slit rod or blue tube ends to make assembly easier.

Abrasive paper

### Pencil and Rule

Use to mark lengths of blue tube or slit rods before cutting. Can also be used on plastic sheet before shapes are cut out.



## ALSO NEEDED

Clear tape and

2 x standard AA batteries

**Hole punch** - to punch holes in card

**4mm drill** - optional to make hole on card OR cut with scissors then tape access slit afterwards



**SAFETY WARNING**



Care needs to be taken with all sharp tools - Students under 9 years old need to be supervised by an adult.

Never use rechargeable batteries as they can catch fire if the circuit is shorted

Making Instructions  
2 Pages

Laminated sheets  
Top

3

# Kre8® Go and Fetch Robot - Photos 2

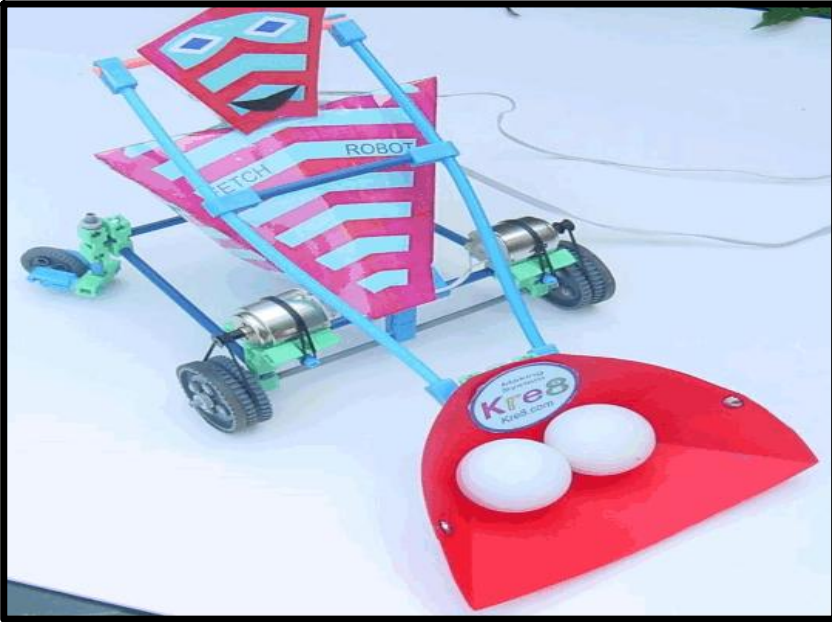

General views

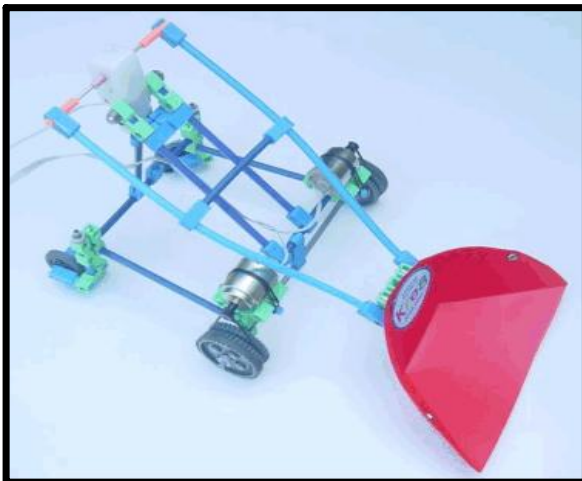
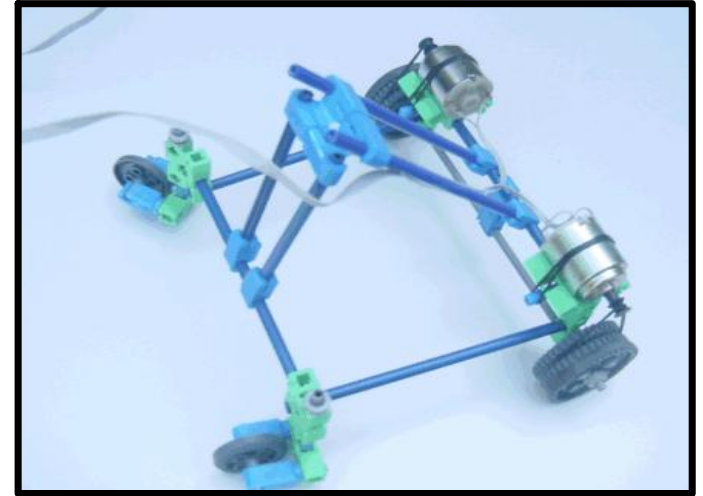

Geared down motor



Wires on geared down motor

4

# Kre8® Go and Fetch Robot - Photos 2

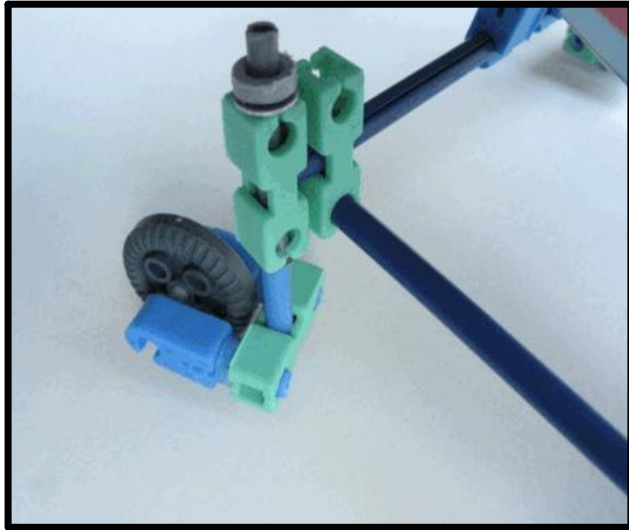

caster wheel in use

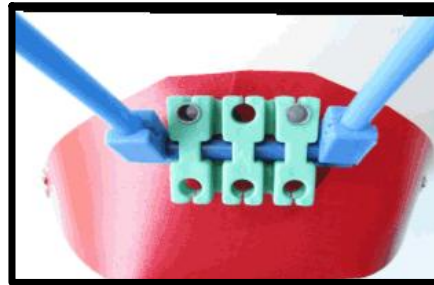

Back of bucket

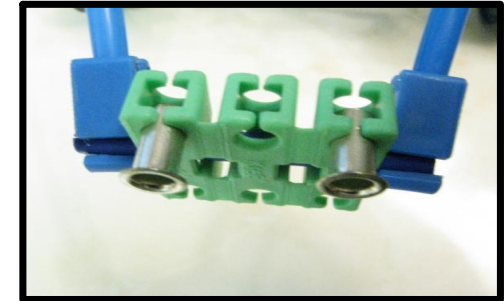

Using 'bearing' as fixing method to hold bucket on front



caster wheel assembly



Bucket before fasteners used to hold it together

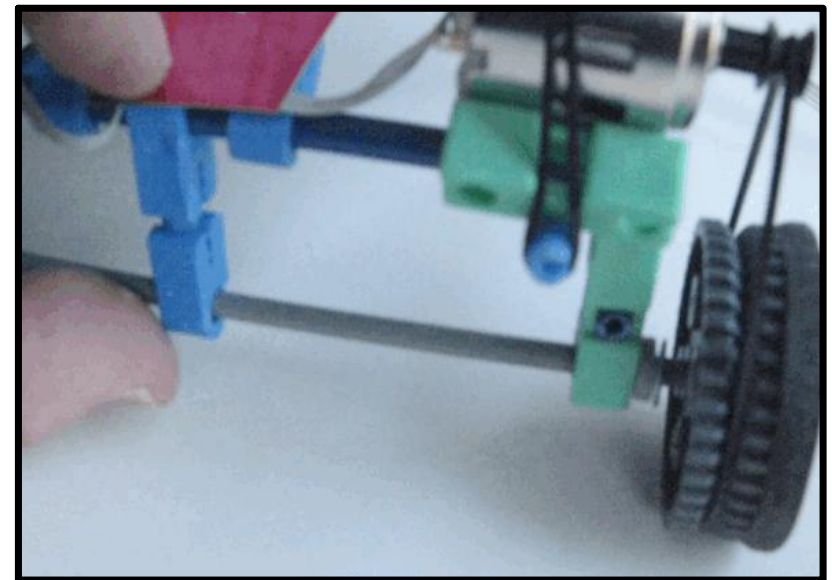

Front axle and drive detail

# 5

## Kre8® Rescue Robot - Making 1

**Note** - To make assembly easy smooth and round the ends with **abrasive paper** before pushing and twisting into the connectors.  
**All sizes in mm**

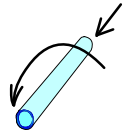

1 See Sub - Assembly page to make wheels  
page 7

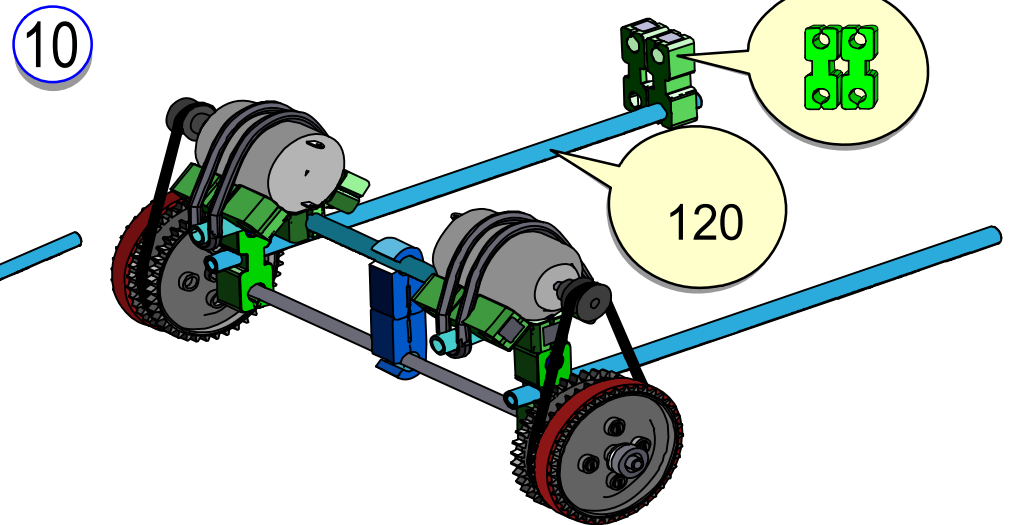
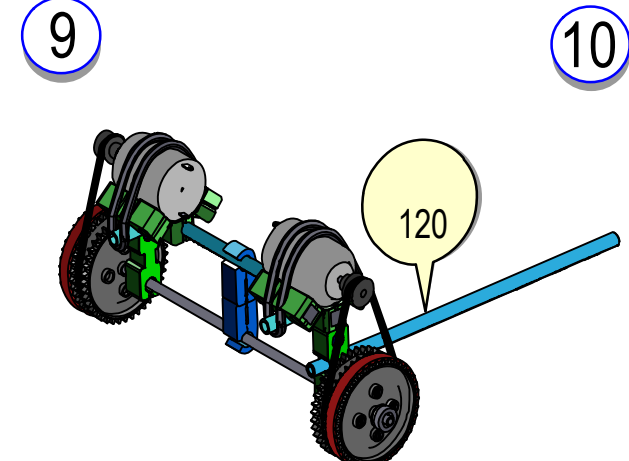
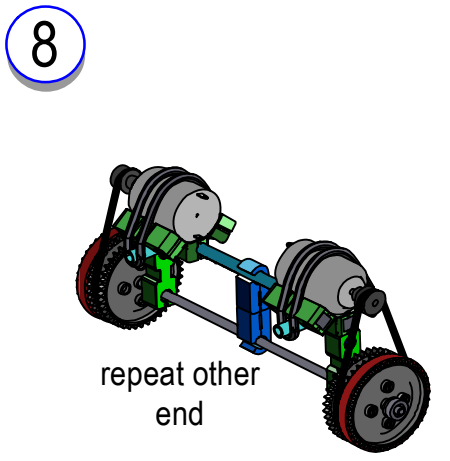
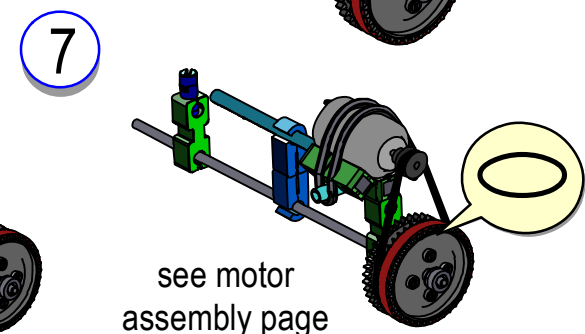
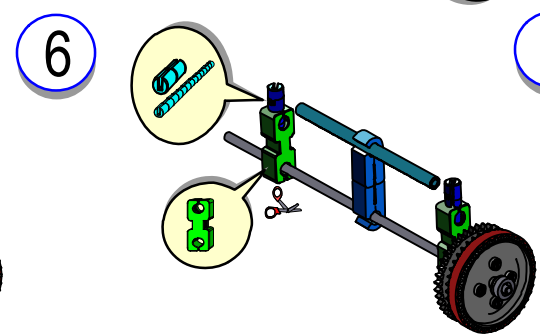
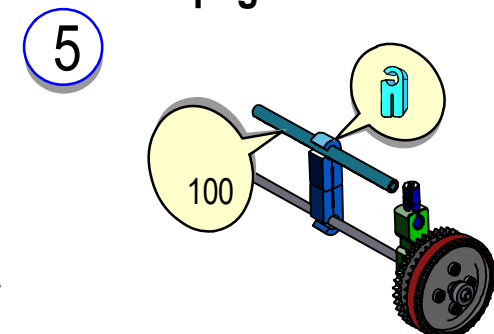
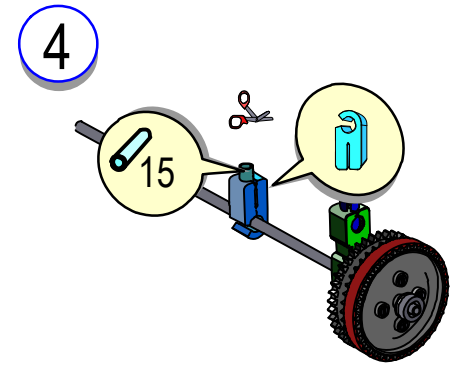
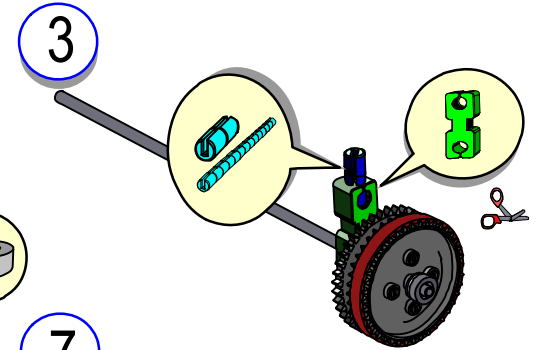
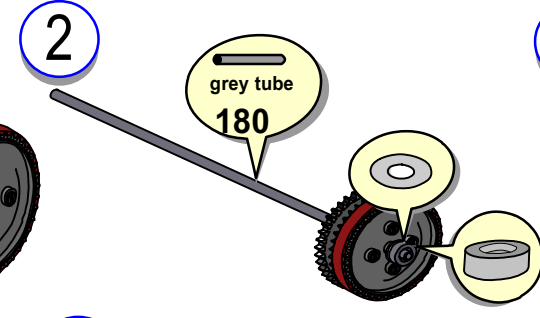

# 6

# Kre8® Rescue Robot - Making 2

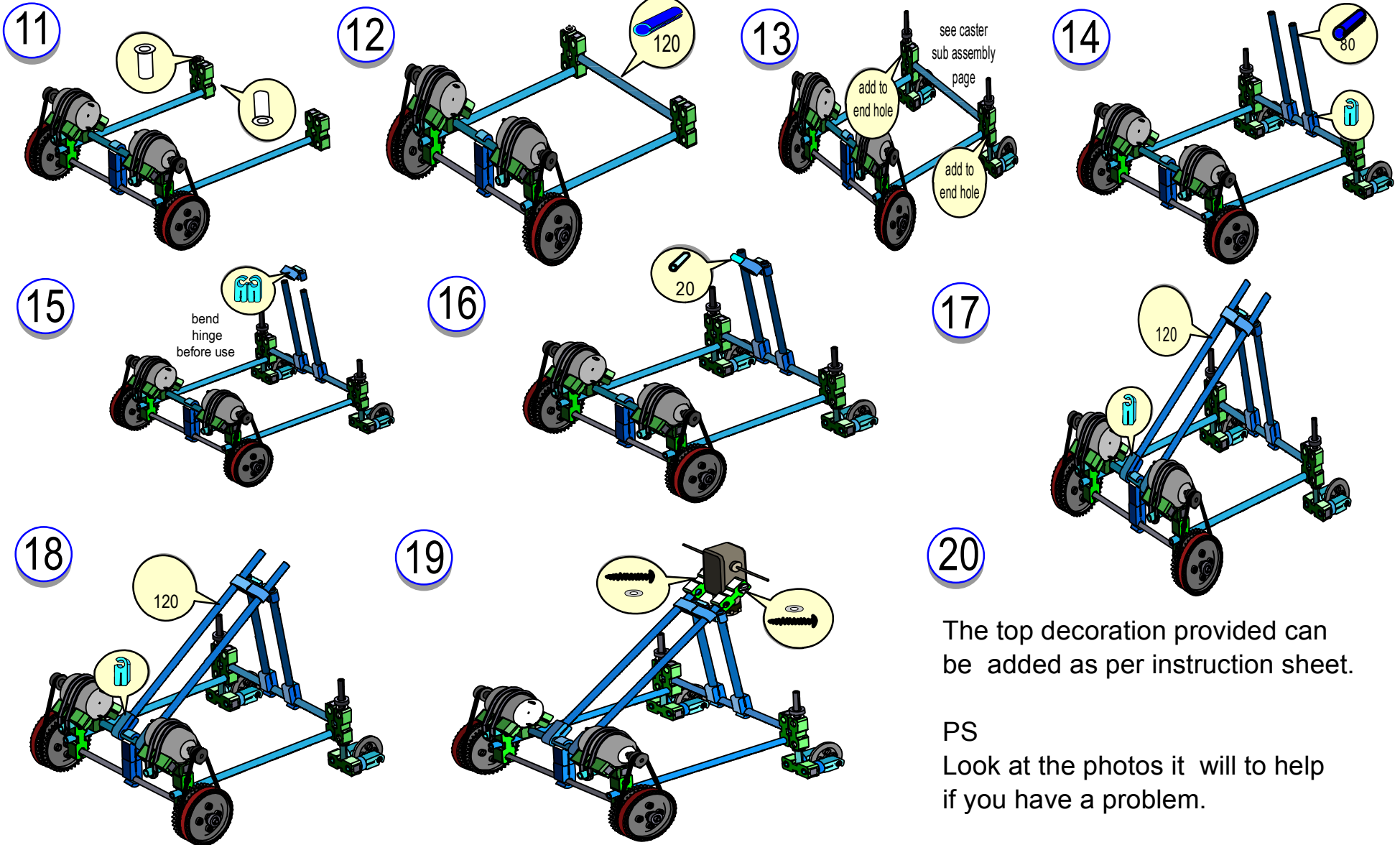

# Making a Motor Assembly - 2 NEEDED

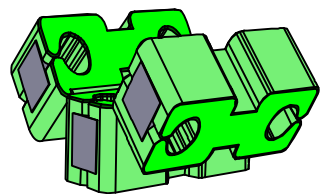

bend sides upwards

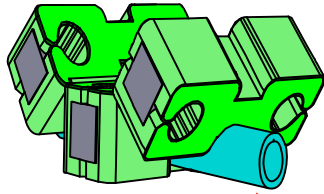

twist and push in central hole

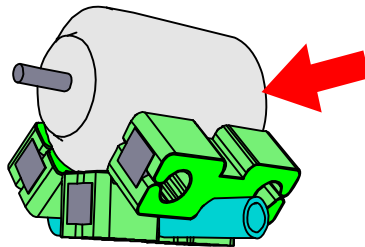

lay motor in place

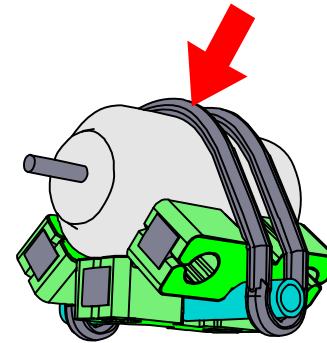

Loop short rubber band over the top

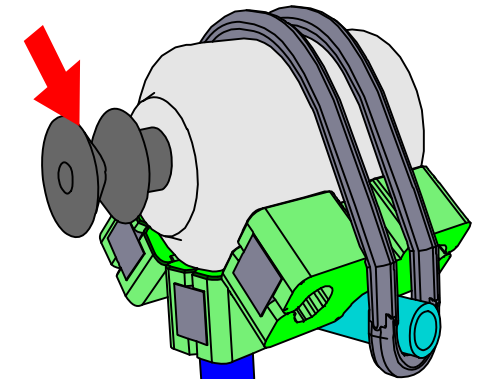

Add pulley

8

# Sub - Assembly - Caster wheel

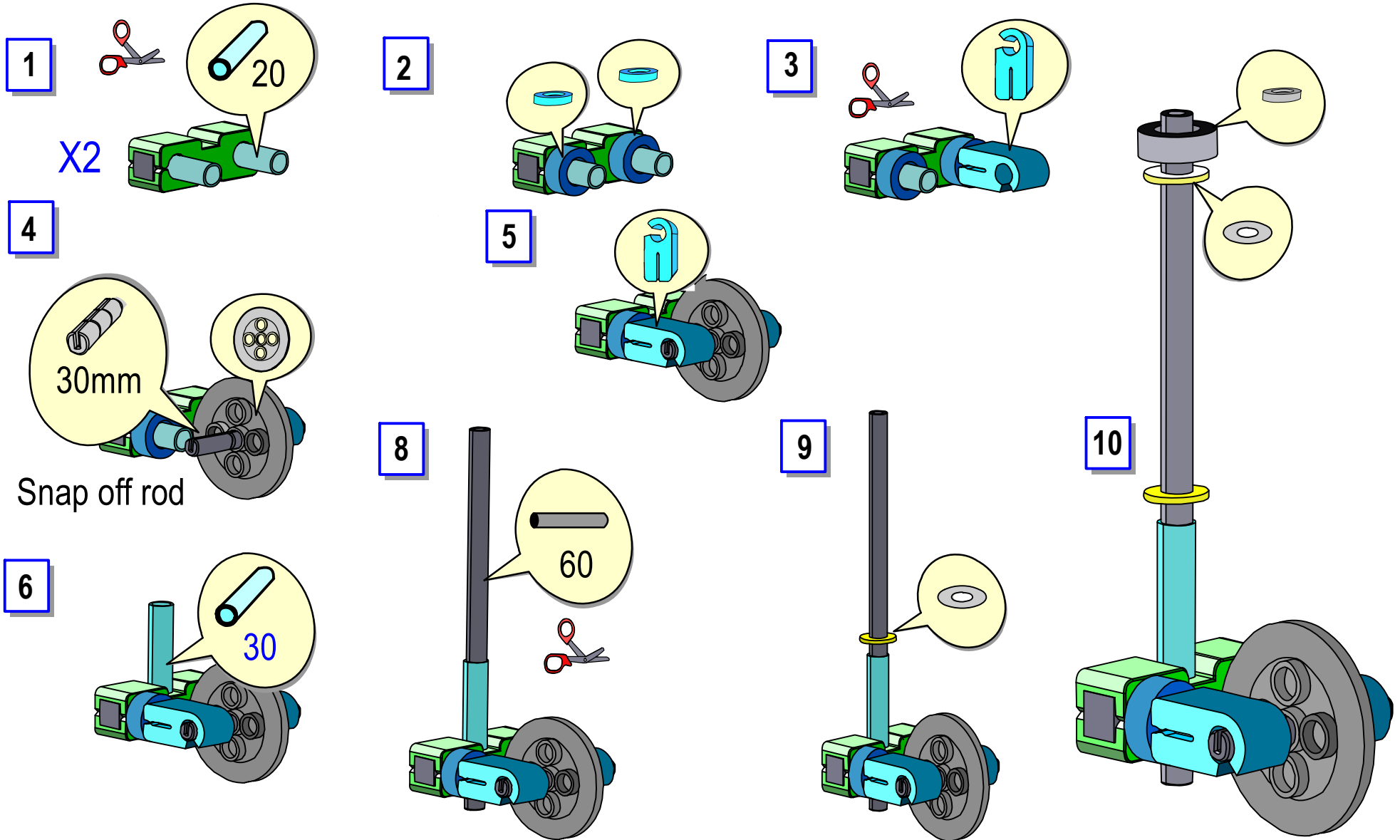

# 9

# Making Wheels and Top Arm

## Making Wheels

1

Place in hole and snap off 2 sections long

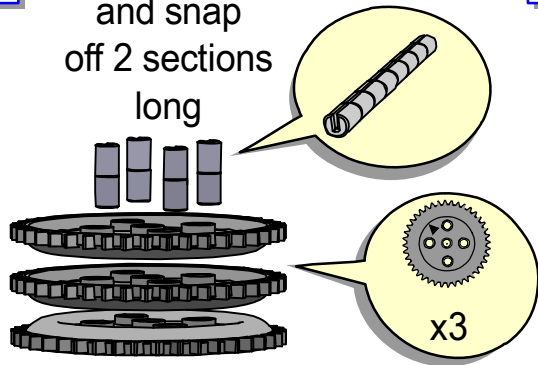

2

Assemble and 'tap' / push rods into place (can trim extra with side cutters if wanted)



3

Add rubber band

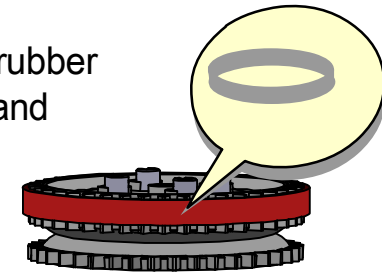

## Making Top Arm Part

1

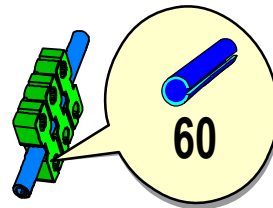

2

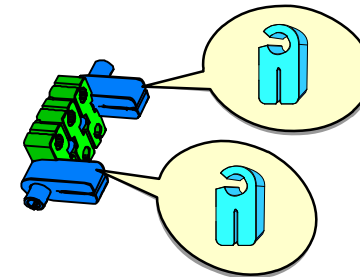

3

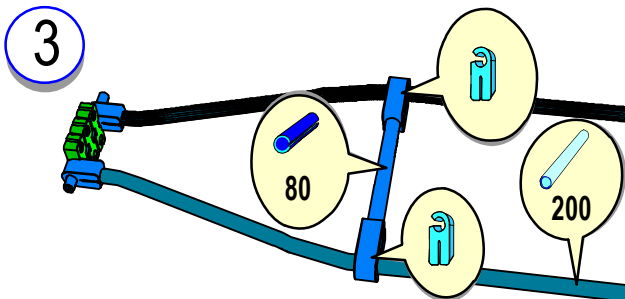

4

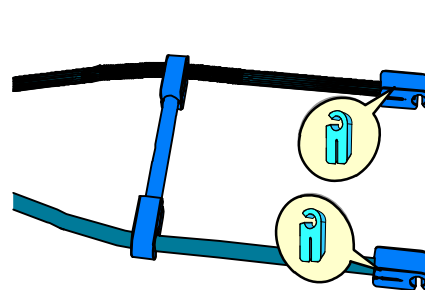

5

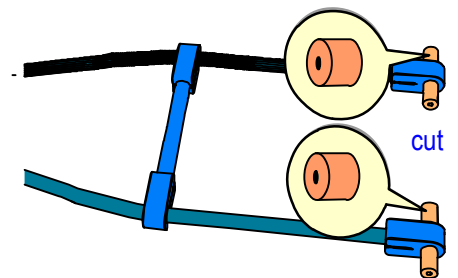

# Kre8® Rescue Robot - Possible Top

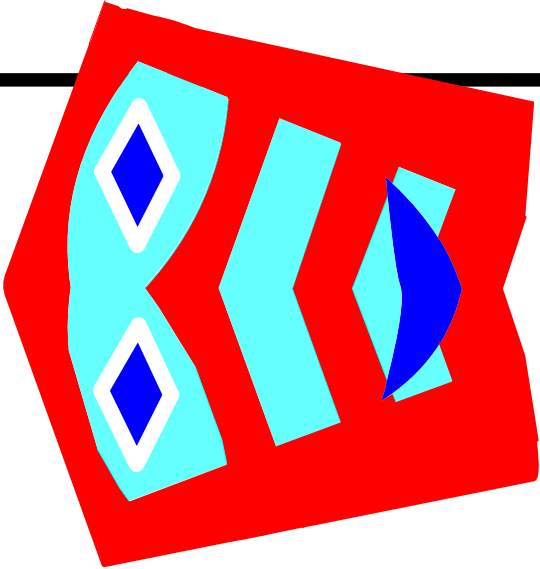
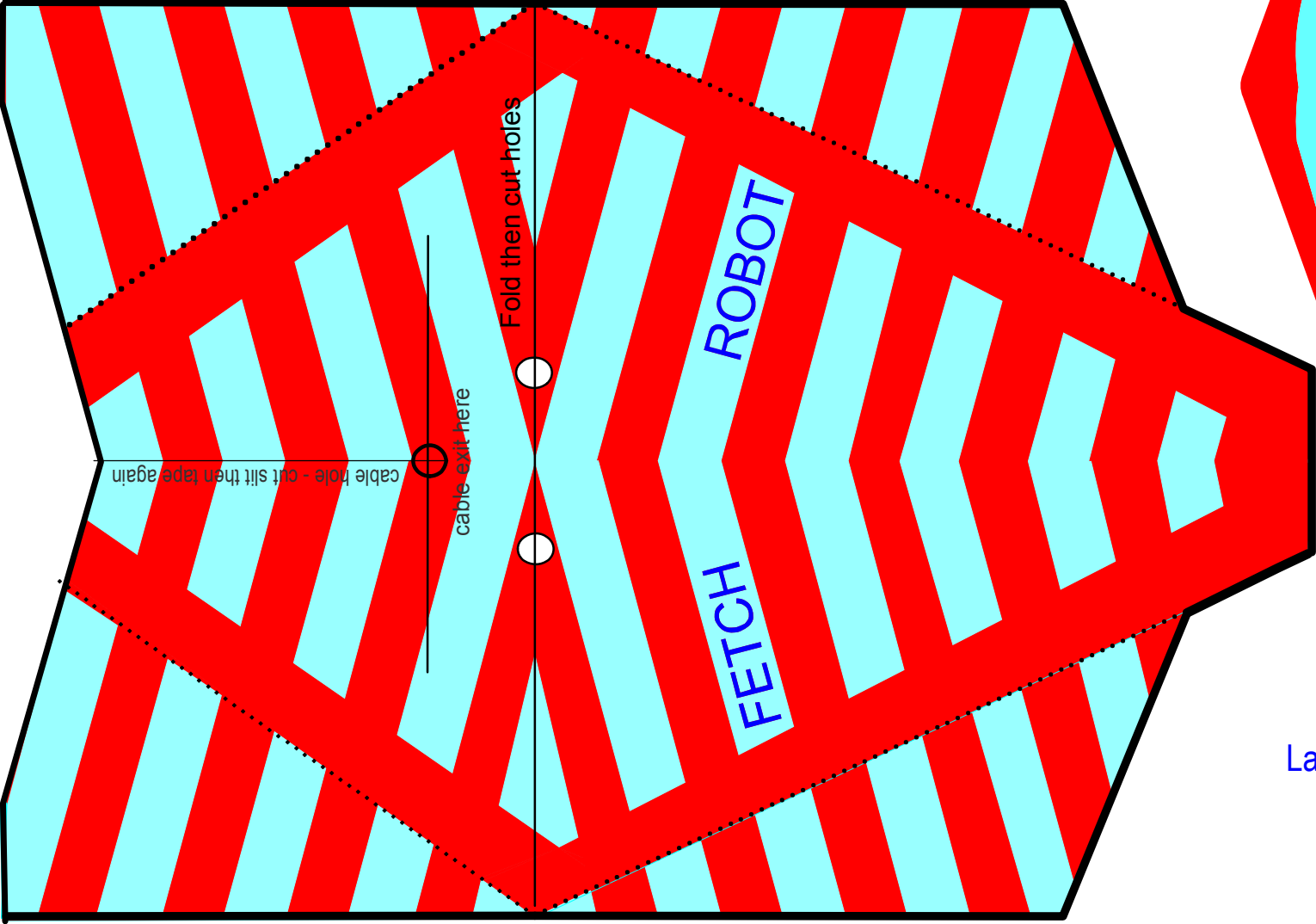

Laminate this page then cut out

# 11

## Kre8® Hand Controller - adding the cable

Then use to steer and control your robot remotely using the long cable provided.

NEEDED (comes with kits)

- length of ribbon cable
- Robot with two motors
- Kre8® hand controller

Tools :-

wire strippers and small screwdriver

1

Note - This kit uses 6 wire ribbon cable

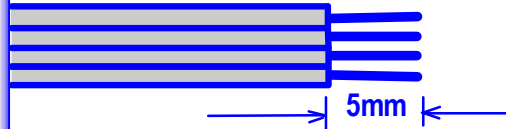

Strip one end of the ribbon cable 5 mm long from the end.

2

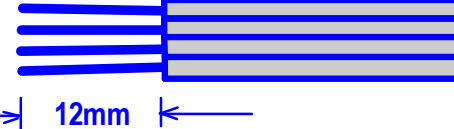

Strip the other end of the ribbon cable 12 mm long (to attach to the motors).

3

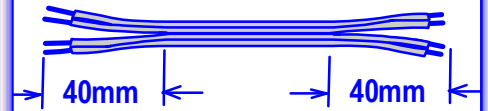

Split the ends into PAIRS of cables about 40mm long - can use scissors to help.

4

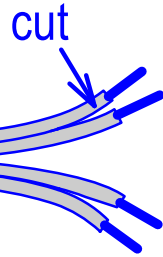

Next split the pairs of cables into single wires. Repeat for other end.

5

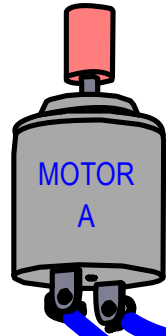

Thread 12mm stripped wire through the motor terminal holes, then twist.

6



Connect motor B as you did motor A.

7

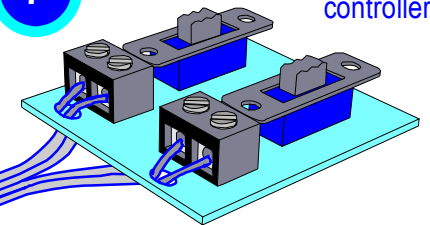

Add cable to Kre8® hand controller

Thread wires through the holes, then insert wires in the connectors and tighten screws.

8

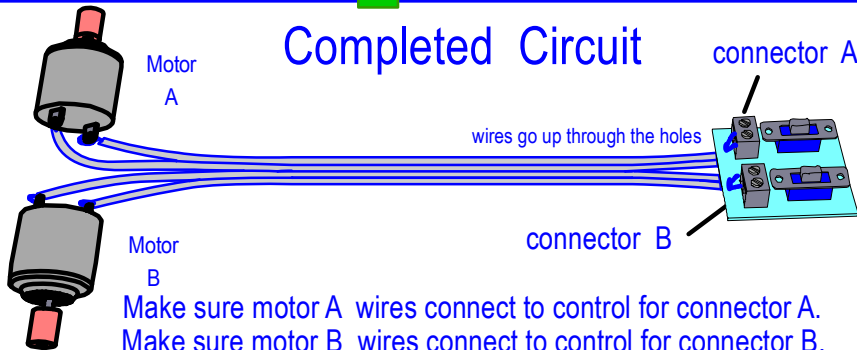

Completed Circuit

Make sure motor A wires connect to control for connector A.  
Make sure motor B wires connect to control for connector B.

9

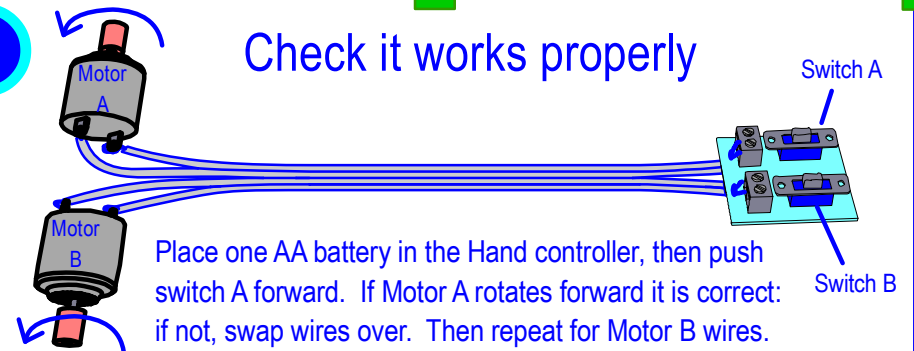

Check it works properly

Place one AA battery in the Hand controller, then push switch A forward. If Motor A rotates forward it is correct: if not, swap wires over. Then repeat for Motor B wires.

12

# Possible Bucket Idea

Full Size Template

\*\*\*\*\*

Transfer this shape onto the plastic sheet provided then cut out .

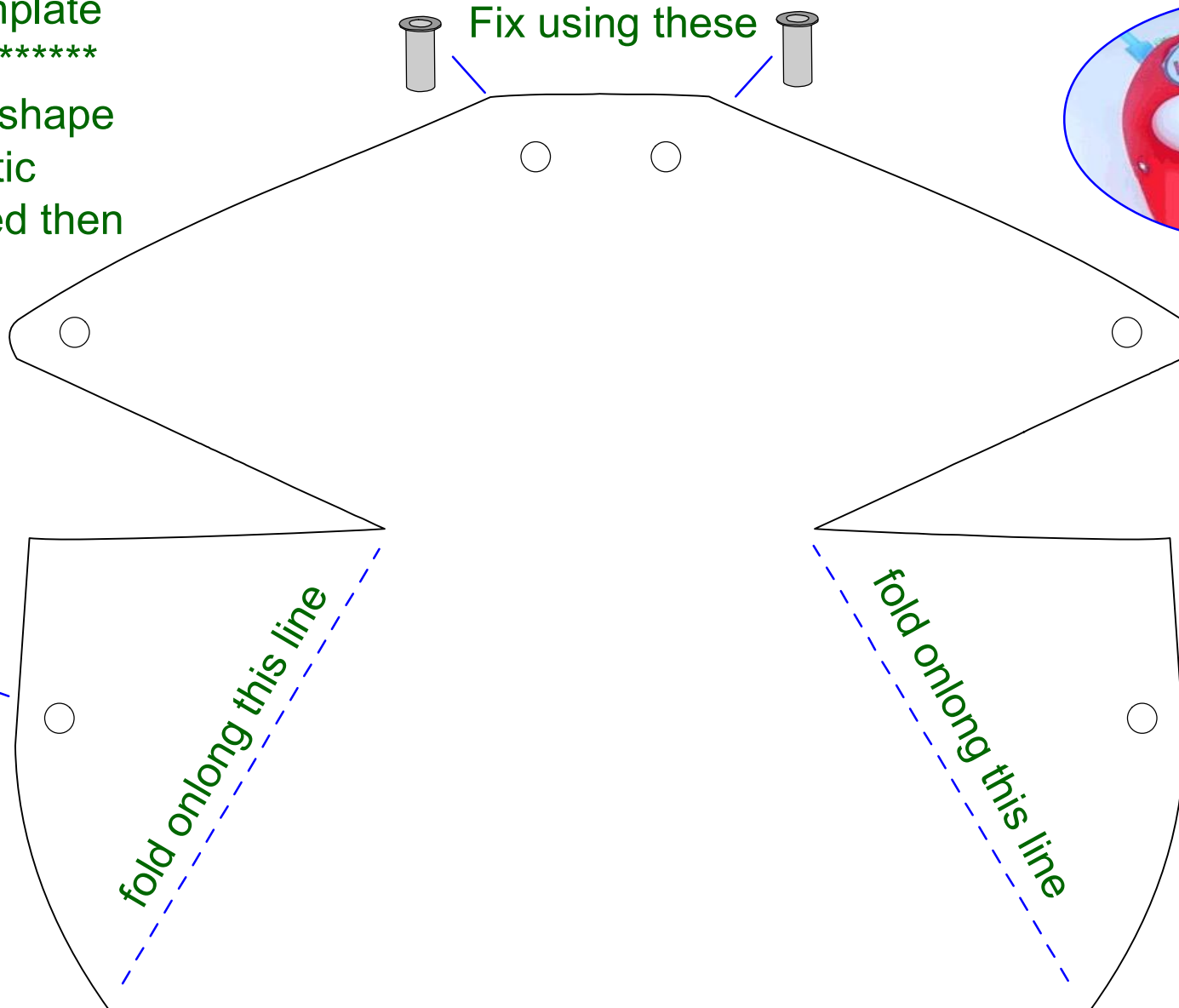

In use

Use paper punch to cut all holes

paper clip

paper clip

13

# DOG TOP IDEA



In use

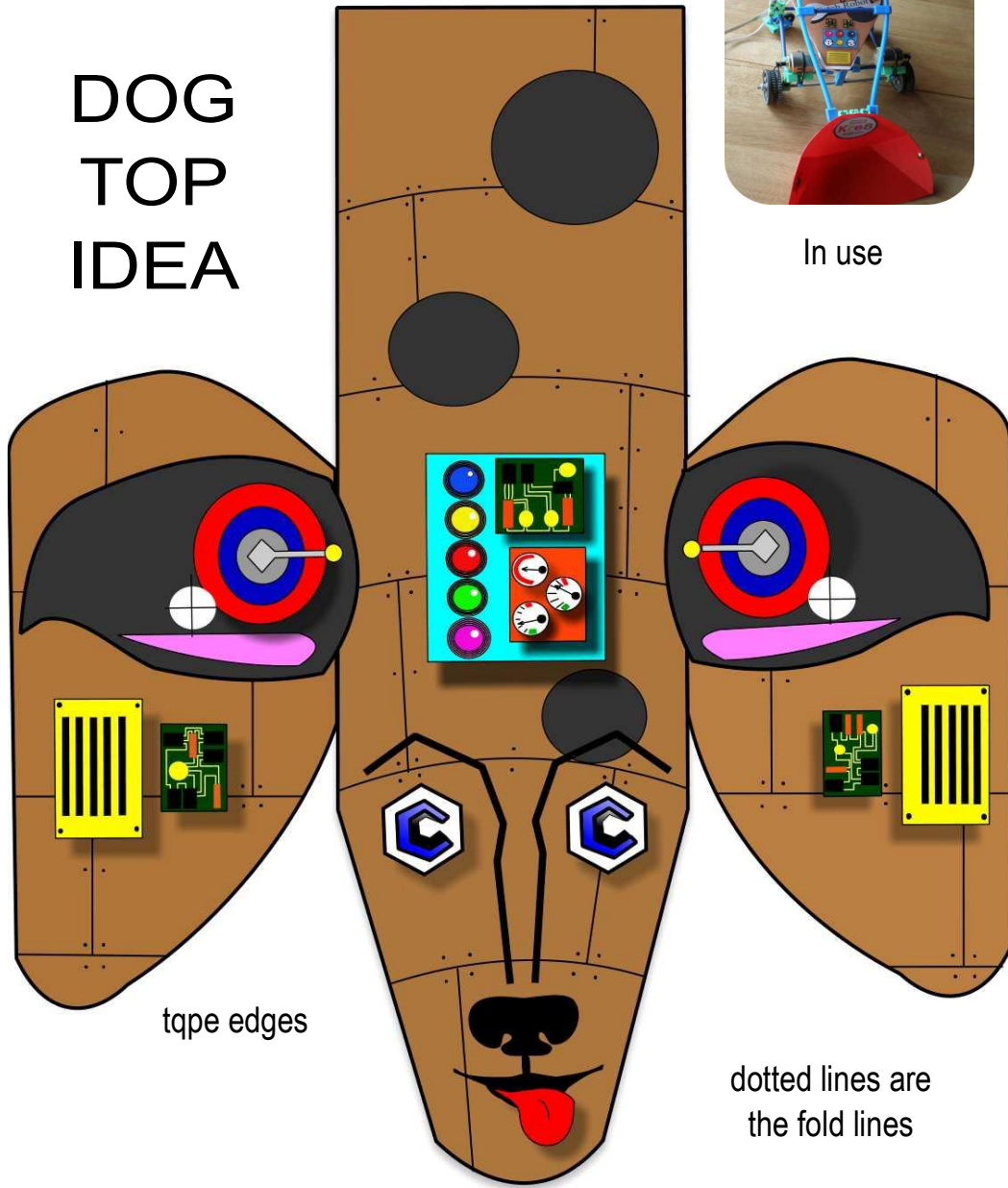

tape edges

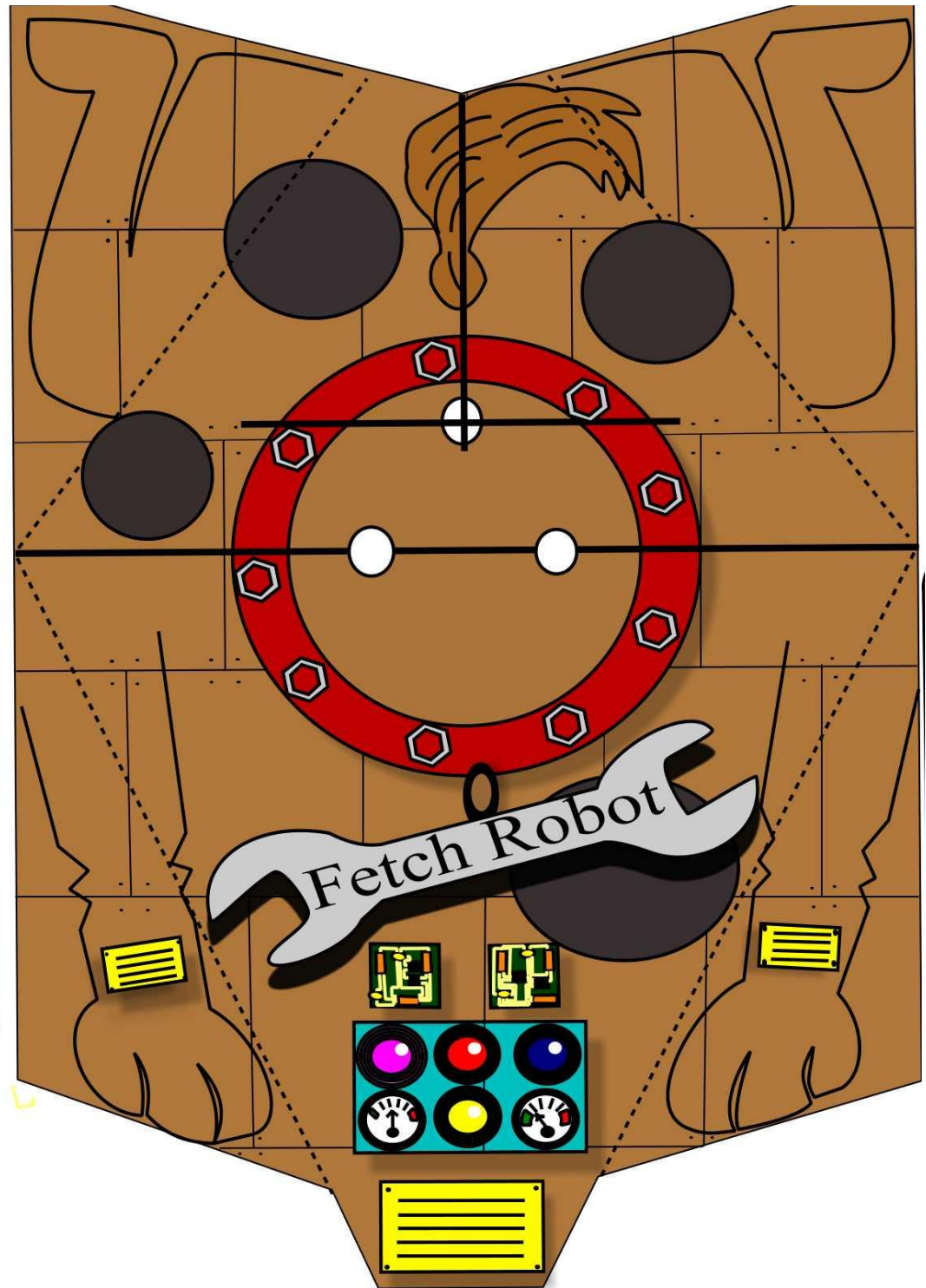

dotted lines are  
the fold lines