

## Introduction Page

### Solar (sun powered) Racer OR battery powered racer

This electric powered racer can be powered using direct **sunlight** (using the solar panel) \* **OR** a **battery** placed in the battery holder provided (AA battery required)

Use on a smooth flat surface. Can be steered by adjusting the front wheels.

If no sun is available the sun can be **simulated** using a portable builders type 500 halogen lamp or similar. (see safety issues)

### Activity

**Tip** - Also see **video**

- Assemble the solar car
- Test in sunshine (direct sunshine) on a smooth surface.
- improve making by any adjustments necessary.

**Or**

*use alternative battery power if no sunshine*

### Competition Idea

- Race against a friends vehicle
- Make changes to see how much you can improve it.
- Devise a way to measure speed over a distance.

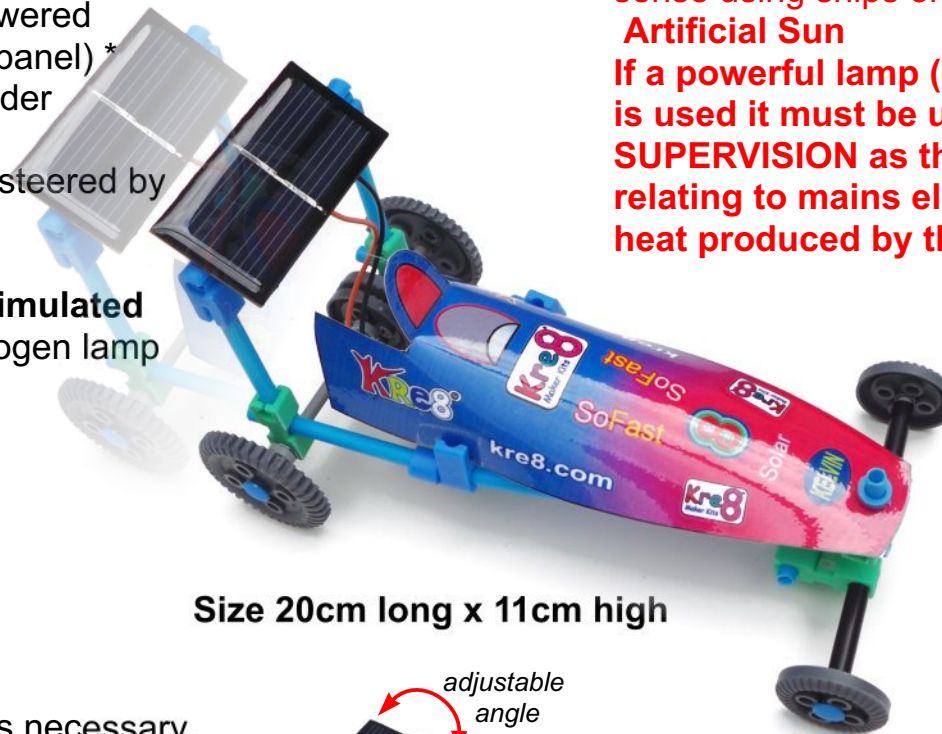

Size 20cm long x 11cm high



With different solar panel

### SAFETY

The model is safe but requires basic common sense using snips or scissors.

### Artificial Sun

If a powerful lamp (e.g. 500Watts halogen) is used it must be used under **ADULT SUPERVISION** as there are **SAFETY** issues relating to mains electricity used and the heat produced by the lamp.

### Keywords / Knowledge

Electricity, energy conversion, kinetic energy, solar power, aerodynamics, rolling resistance, friction, testing, efficiency, power, voltage, current, speed and safety.



2 x Kre8 blue connector

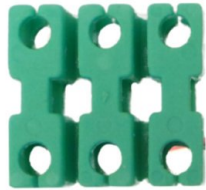

4 x Kre8 green connector

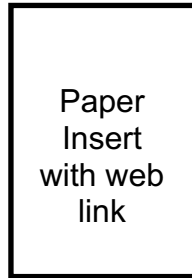

Paper Insert with web link



2 x Kre8 band long 60mm



2 x Kre8 blue collars

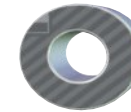

4 x Kre8 grey collars



4 x Kre8 28mm wheels



2 x Kre8 40mm wheels



4 x Kre8 5mm dia. dark blue tubes 20cm long



1 x Kre8 3.9mm grey tube 20cm



1 x spacer straw



1/2 length of 4mm grey snap rod



4 x Kre8 end caps



2 x washers 4mm hole



1 x foam double sided adhesive tape 10cm long (supplied wrapped round green connector)

## Solar Racer Top V4

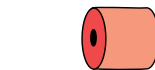
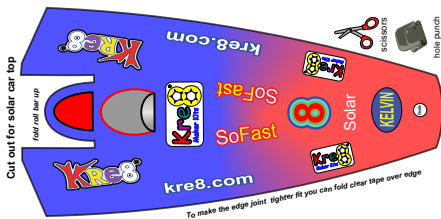

1 x orange tube (pulley)



1 x abrasive paper (small piece)

## Electric Parts



1 x electric motor (larger type)



1 x AA battery holder



1 x solar panel 68 x 48mm (type may differ)

## Tools you may need



abrasive paper

can use to round ends of tube to make assembly easier



Not Supplied

snips or scissors



pencil

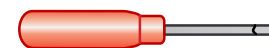

screwdriver



ruler

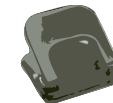

paper hole punch

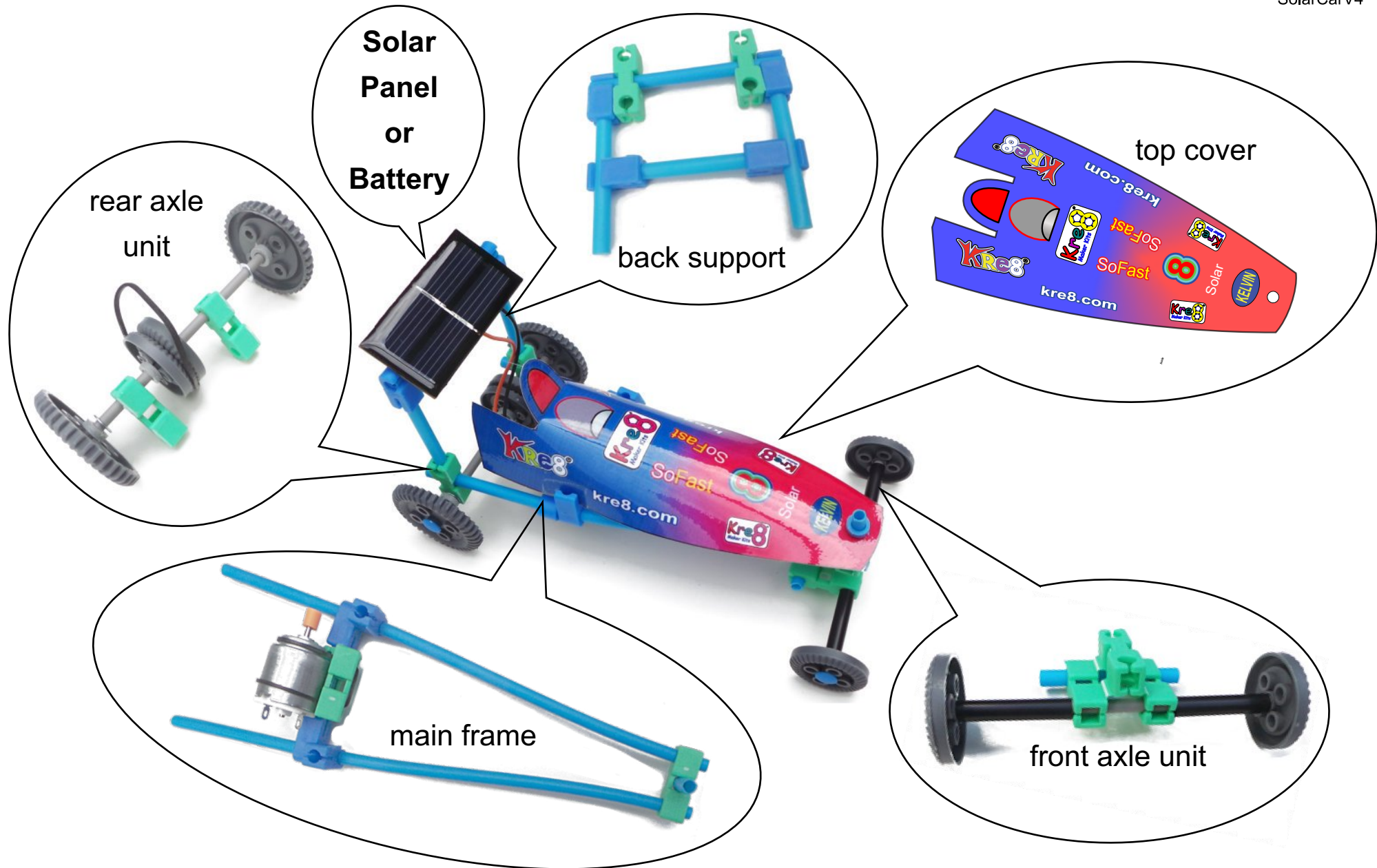

**MAKING NOTES** ALL SIZES METRIC

- 1) **ONLY** cut up connectors as needed
- 2) Use a metric ruler for measuring
- 3) For **EASY** assembly -  
Round the end of the tubes with **abrasive paper** then **push and twist** rods into place
- 4) **Protect** table from damage.

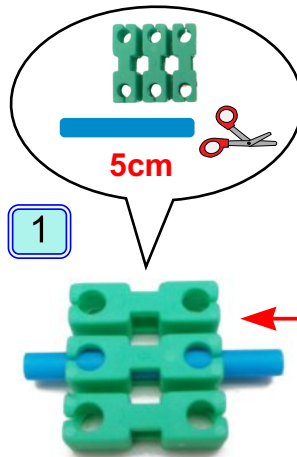

Insert the 5cm long blue tube

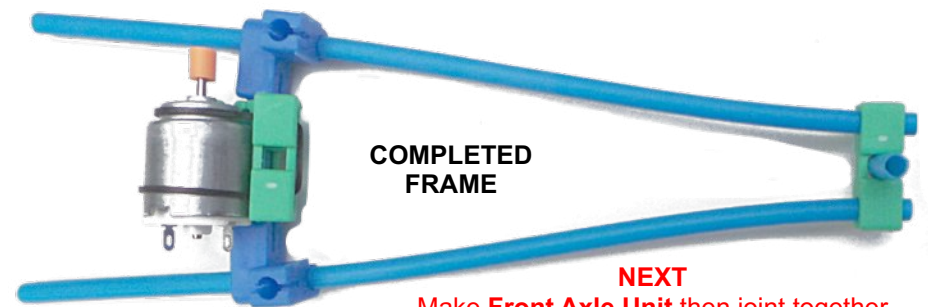
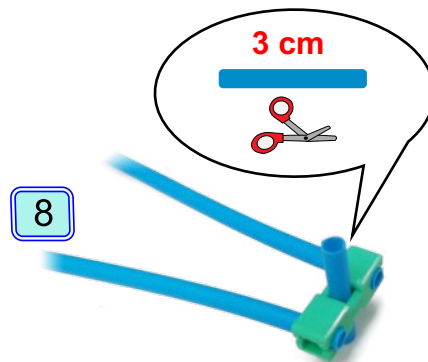
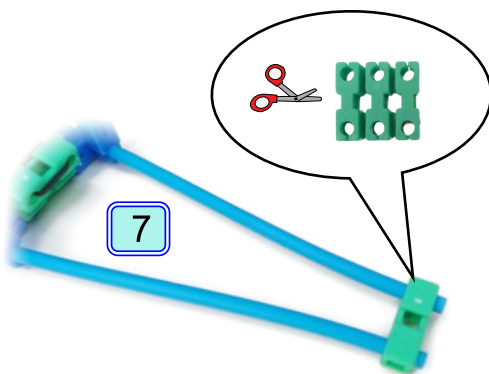
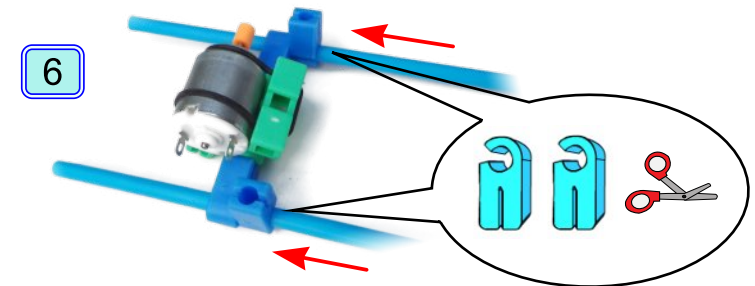
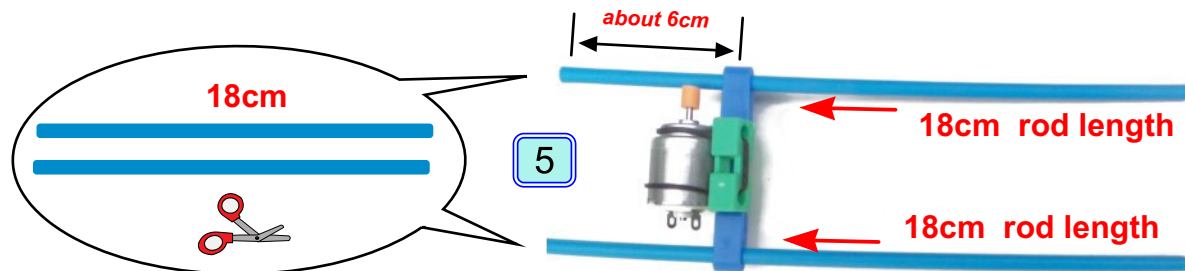
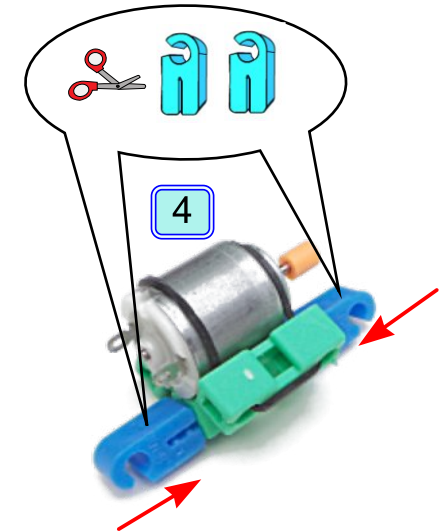
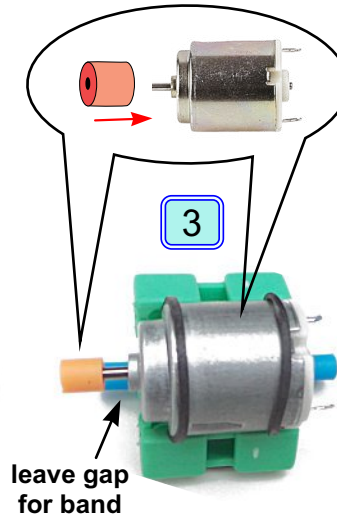
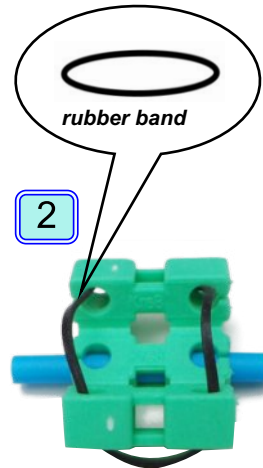

**COMPLETED FRAME**

**NEXT**  
Make Front Axle Unit then joint together

## Front Wheels

9

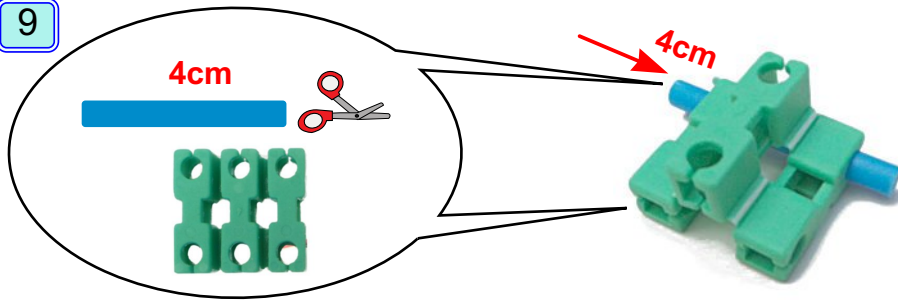

10

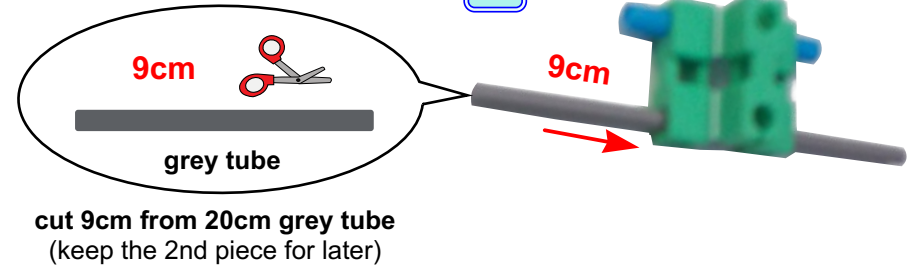

11

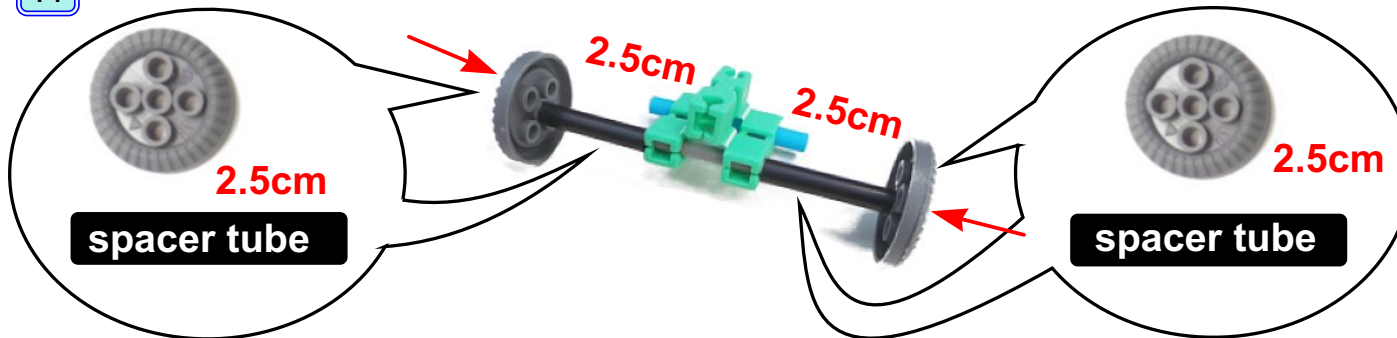

12

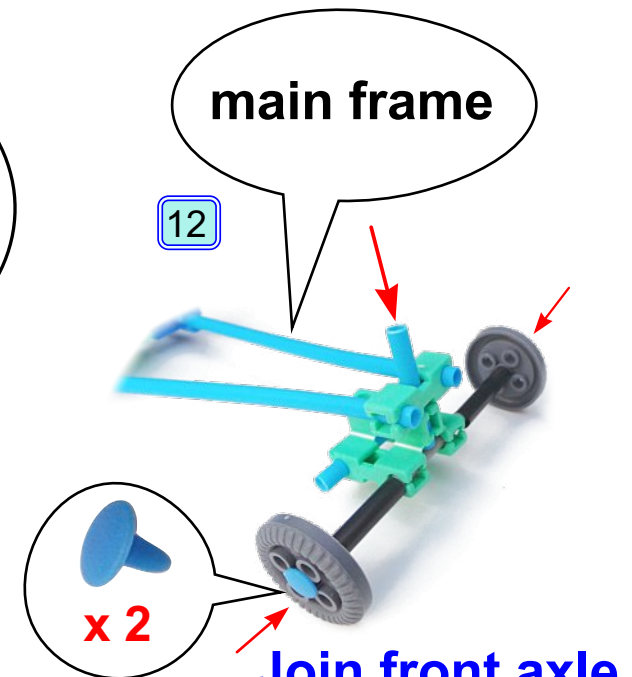

See Next page for 'Rear Axle Unit'

13

## Making the 28mm dia Pulley

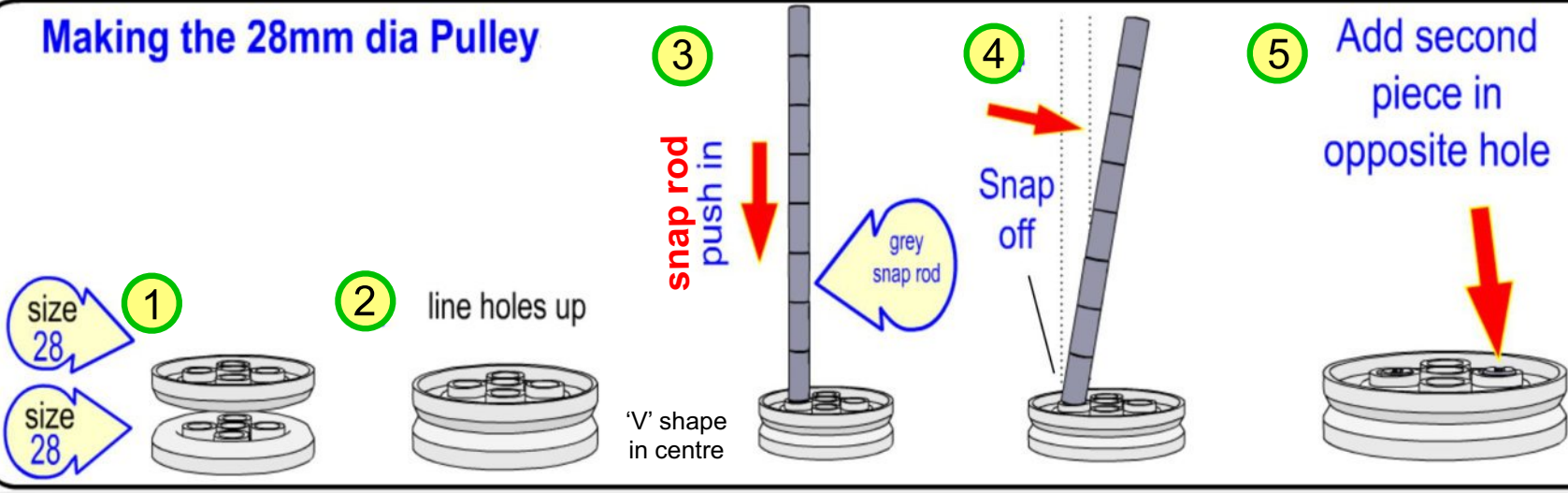

14

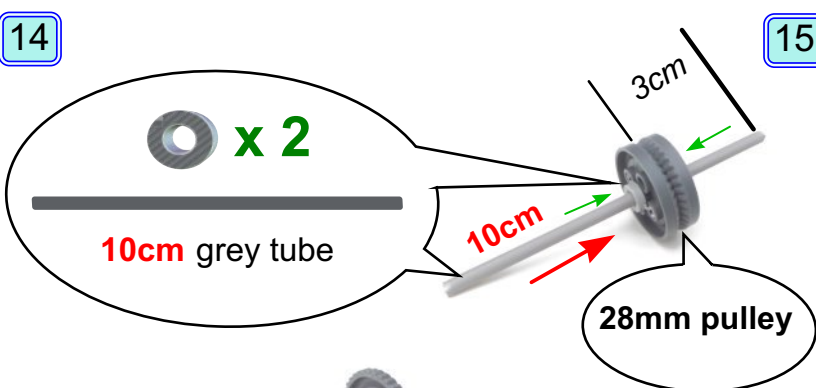

15

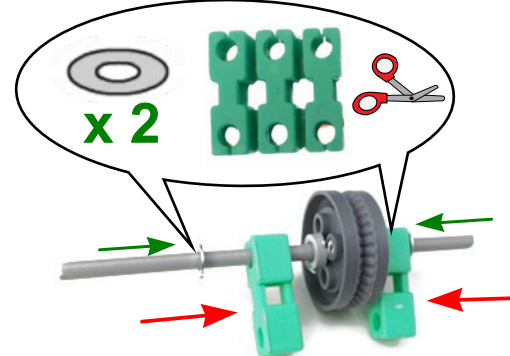

16

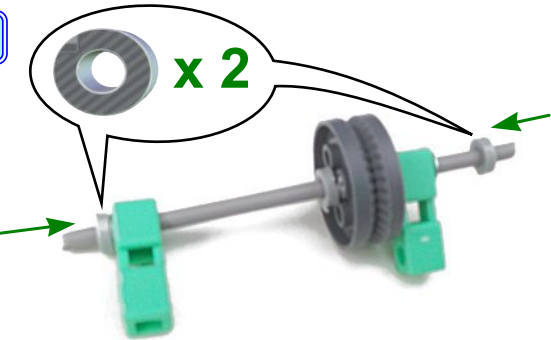

17

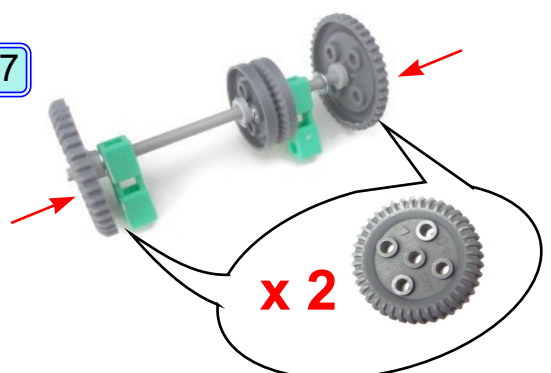

18

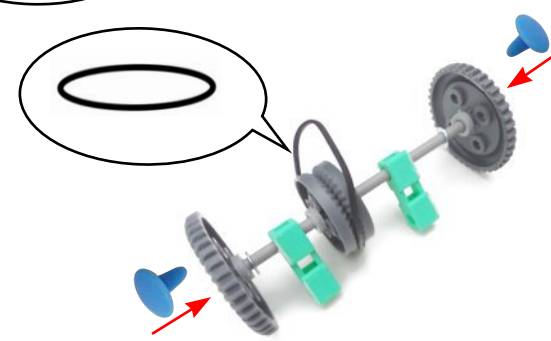

19



**Then join to main frame**

20

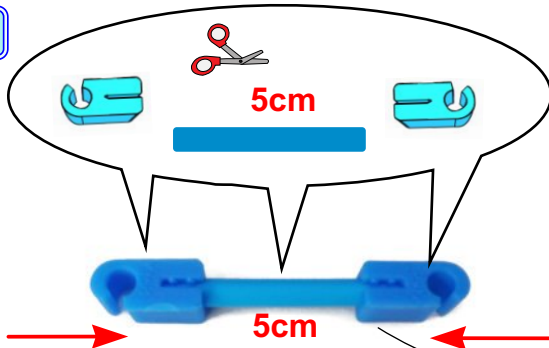

21

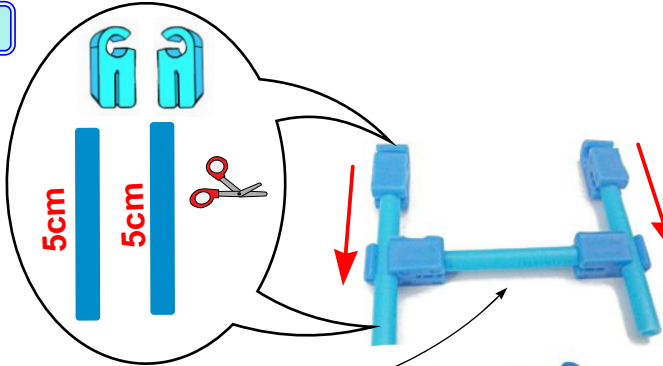

22

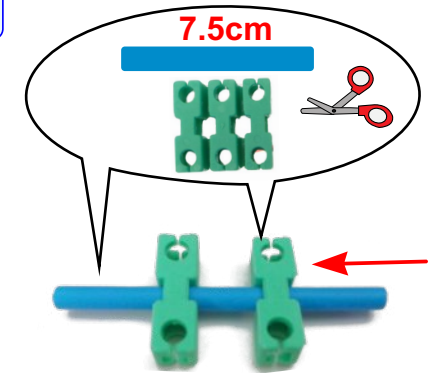

23

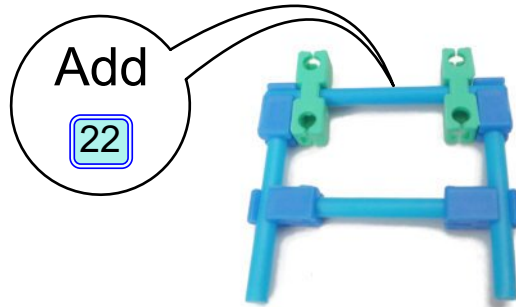

24

Add back support to main frame

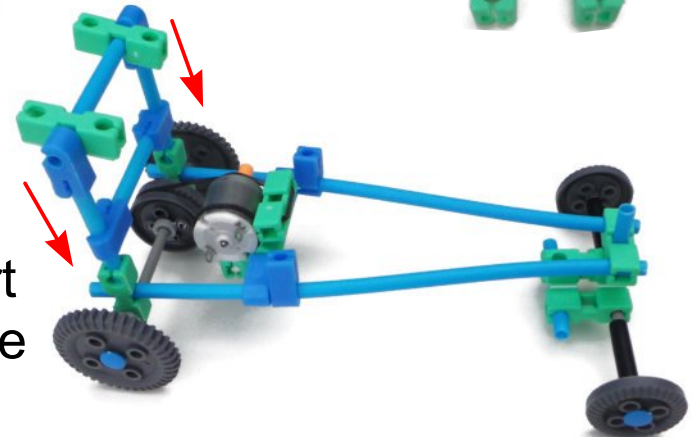

24A

## Aligning pulley with motor

Adjust pulley so it is 'in line' with the motor as shown to avoid the rubber band drive falling off when it rotates.

Note  
Final adjustment is best made later

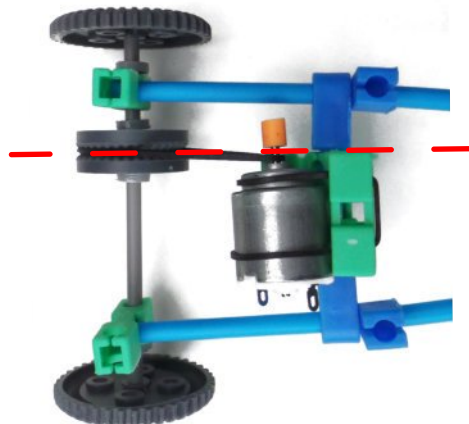

24B

Adjust motor position so spindle part is below the main frame as shown.

**IMPORTANT**  
The rubber band only just needs to grip the motor pulley to get best result.

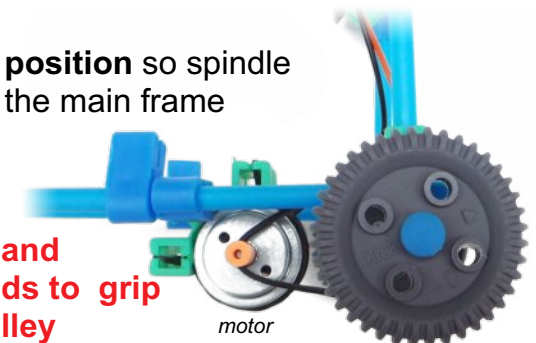

Side View of motor

## Adding the Top

25



Cut out TOP shape and punch hole (see page 11)

26



27



*Option*  
Can thicken fixing points with clear tape at fixing points

28



**Note**  
When testing it is easier to leave top off

29

## Adding Solar Panel

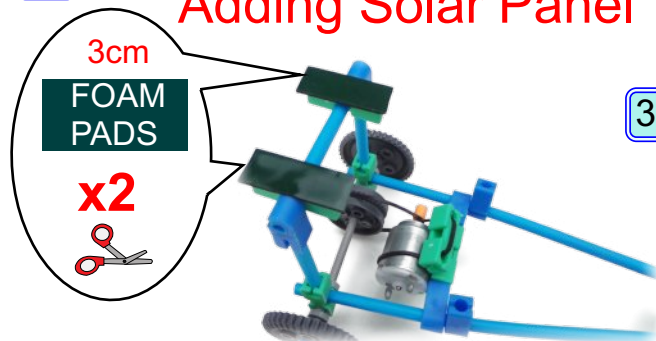

30



Peel top covering off to reveal adhesive

31

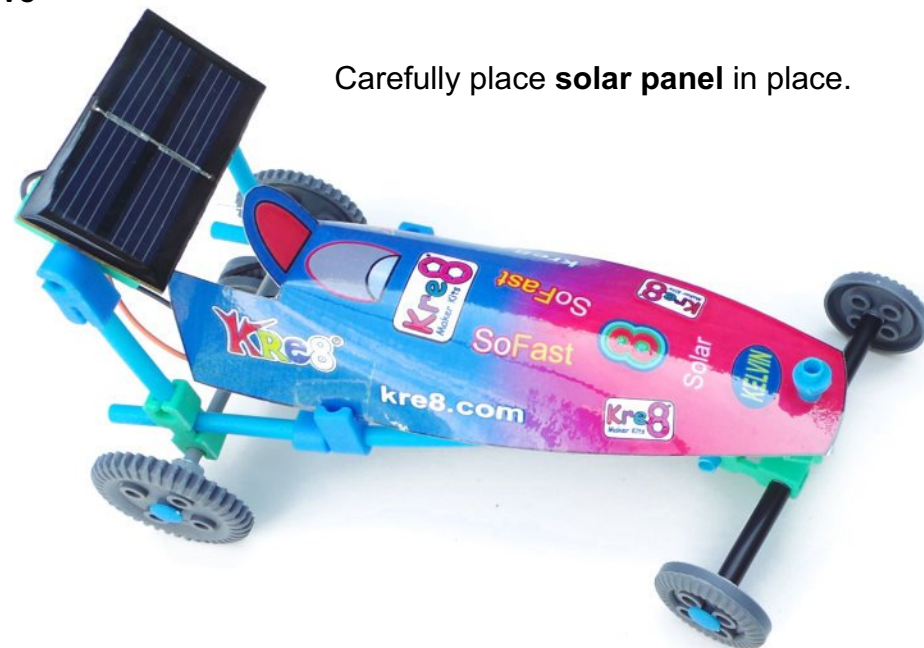

Carefully place solar panel in place.

32

## Connecting wires to motor

To ensure motor rotates the correct way connect the black wire to connector with indent hole.

Place wires through the hole in the connector and then bend over tightly.

**Note**  
The plastic wire covering can be stripped back to reveal more bare wire

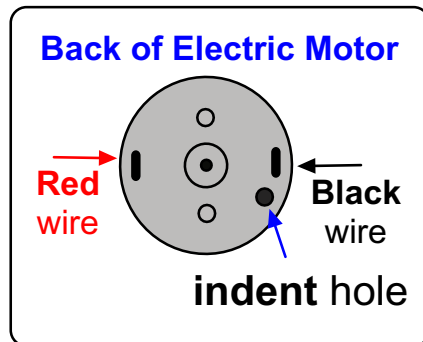

### Adding a Battery Holder



### Switch Idea

A simple switch can be made using a piece of plastic. (e.g. from yoghurt lid) placed at end of battery as shown. (remove it to turn on)

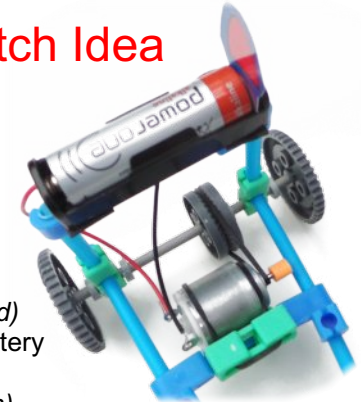

### TIPS

#### Testing the circuit

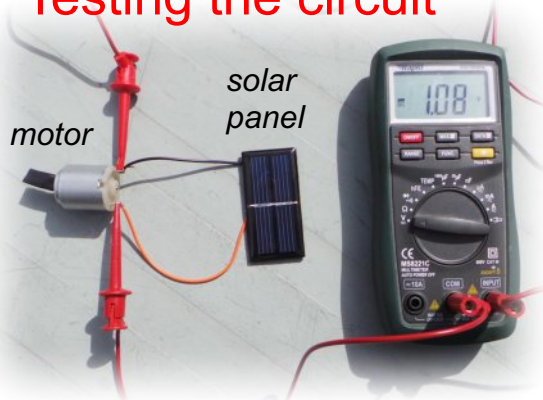

A motor is shown connected to the solar panel. The meter reading reads over 1.08V which is enough to power the motor. (photo taken in autumn sunshine)

#### Pen Mark

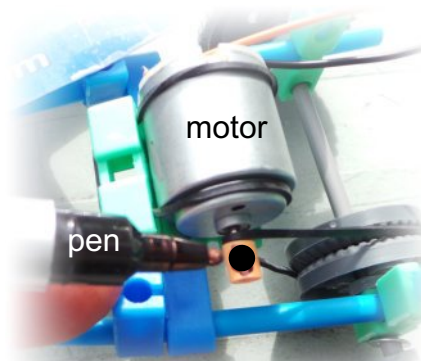

To see the motor spindle rotate you can mark the orange tube with a black pen as shown.

#### Wheels off the ground



Raising the back wheels off the ground can be useful during testing and makes it easy to make adjustments.

Left and Right Side Views



Top and Underneath View

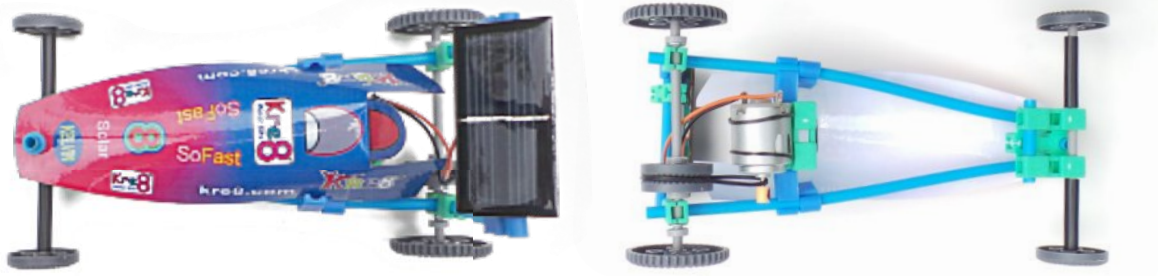

3D View

Back View

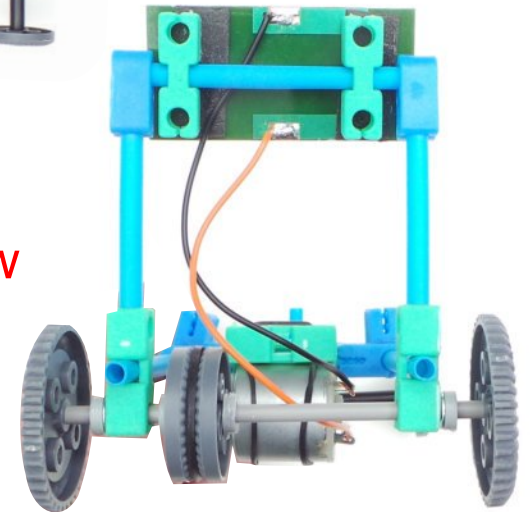

## Cutting up Kre8 Connectors

**ONLY** cut connectors **when needed** because not all connectors may need cutting.

After cutting it is good practice to also **trim** any sharp edges

**Use Good scissors, safety snips or side cutters.**

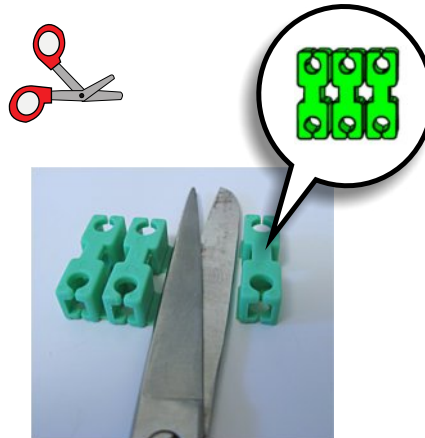

## Making accurate holes with a 'hole punch'

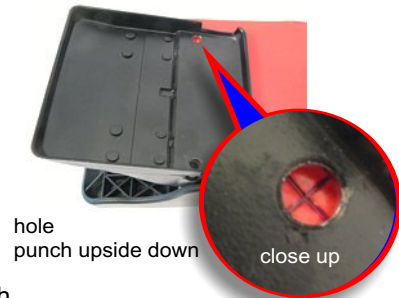

- 1) Remove **back** from hole punch. *(do this over a waste bin to catch any old old cuttings)*
- 2) Use **hole punch** upside down.
- 3) Look through **cutting hole** and line up card.
- 4) **Punch** hole in card

## Possible Problems

### SUN

This **solar model racer** works in **good direct sunshine**.

It will probably not work on cloudy days even if it seems a bright day.

To best **catch the sun** adjust the **solar panel angle**.

### FLOOR

**Smooth flat surface** is required. Use a table if floor too rough.

### FRICION

Make sure the **front wheels** and **rear wheels spin easily**.

(Remove rubber band to test rear wheels)

If the **pulley** just spins adjust the **two grey collars** so they grip the pulley.

The **rubber band** must only have enough tension to turn the wheels. (If too tight it will stop it working)

### PULLEY

The drive **V** part of the **pulley** needs to be '**lined up**' properly with the **motor**.

## PLAN B

If there is **no direct sunshine** available you can use a battery to power the model instead, as shown on **page 9**.



# Solar Car Top

Cut out for solar car top



# Solar Car Top

hole punch

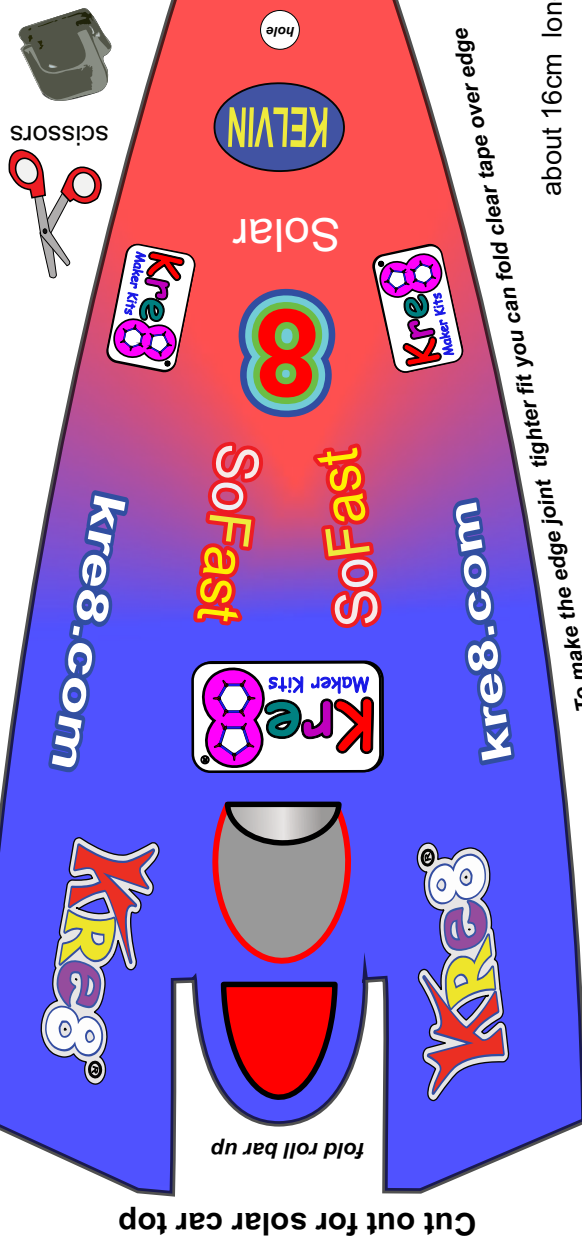

# Solar Car Top

Cut out for solar car top



SolarCarV4