

Contents

- P1 Introduction
- P2 Parts List
- P3 Arch Bridge
- P4 Truss Bridge
- P5 Suspension bridge
- P5 Movie of suspension bridge making

Things you can achieve

Knowledge - Spanning a gap, rigidity, stiffness, enclosing a space, triangulation, mirror image, tension, compression, redundant part.

Making

Assembly and constructions skills - testing then adjusting to get best results

Designing - Make a bridge then use it as part of a townscape design or you could design a new bridge for a particular purpose.

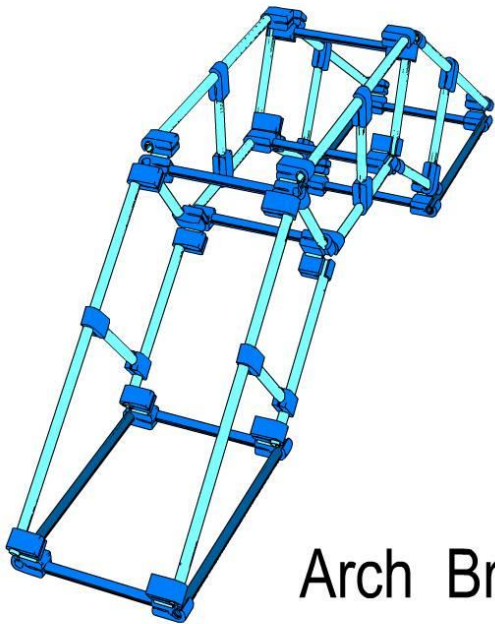

Arch Bridge

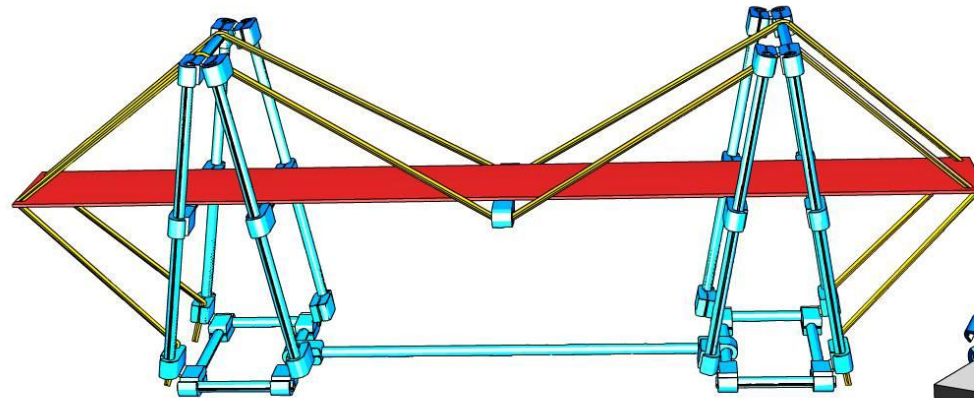

Suspension Bridge

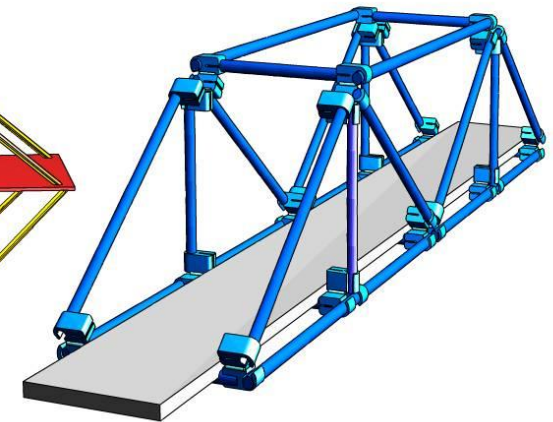





Truss Bridge

check that this rule is correct - it depends on size printed out (should be A4)

Kre8® Bridges - Parts List

Tip - Visit www.kre8.com for movies, zoomable pages and other support









For Instructions print out pages 3 -5

Arched Bridge	Suspension Bridge	Truss Bridge	Max pieces
12	12	0	12 
8	6	4	8 
4	0	4	4 
0	0	6	6 

For Easy Assembly
 Round the rod ends using the emery paper

emery

The rods are easier to insert into the connectors if twisted as they are pushed in. Younger students may need to 'round off' the tubes ends with the abrasive paper.

Parts Supplied in the kit			(parts supplied)		Clip connectors 	Tools needed  
				14	Slit rods 	
	12	17	11	17	8cm	
	4	0	8	8	12cm 	
	4	5	6	6	20cm 	
	7	0	0	7	20cm Light blue rods - can be cut to size needed 	
	1	1	1	1	Road - 6cm wide x 50cm long thick card or plastic strip	
						
			1	String - 2m long medium thickness		

3

Kre8® Truss Bridge - Working Drawing



Tip - Visit www.kre8.com for movies zoomable pages and other support

Making

- (1) Start with the FRONT making sure all connector holes face away from you
- (2) Make BACK part but with connector holes facing towards the FRONT.
- (3) Join the front and back together using 10cm slit rods
- (4) Add the road strip - lay on top of the support rods

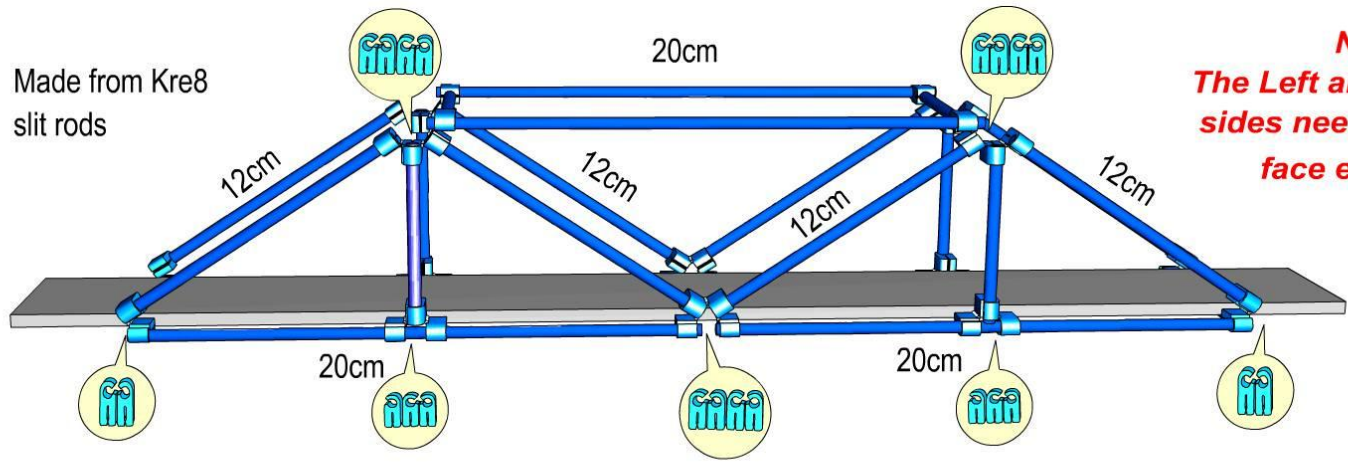

Made from Kre8 slit rods

NOTE
The Left and Right Hand sides need the holes to face each other

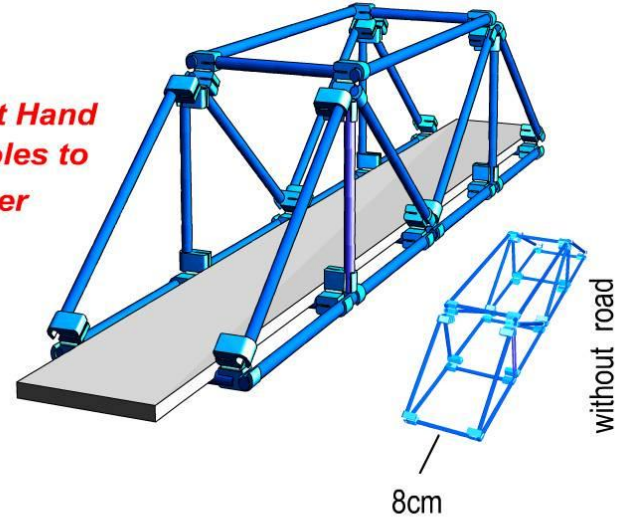

FRONT VIEW

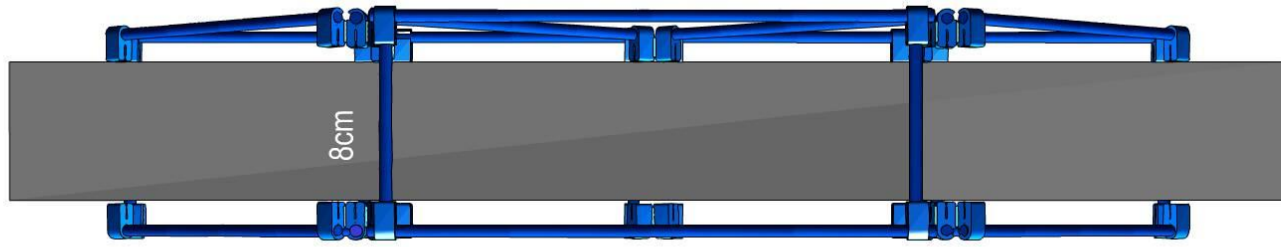

TOP VIEW

Truss bridges can span quite long distances over roads or a river as shown below .

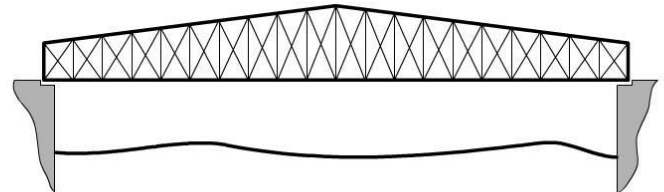

4

Kre8® Arch Bridge - Working Drawing

Tip - Visit www.kre8.com for movies, zoomable pages and other support



Making

- (1) Start with FRONT part making all the connector holes facing upwards if laid down when assembling NOTE - The ight blue parts marked need to be cut to length using snips or sharp scissors.
- (2) Make BACK part to MATCH the FRONT (so you have left and righthand version)
- (3) Join the front and back together using 10cm slit rods

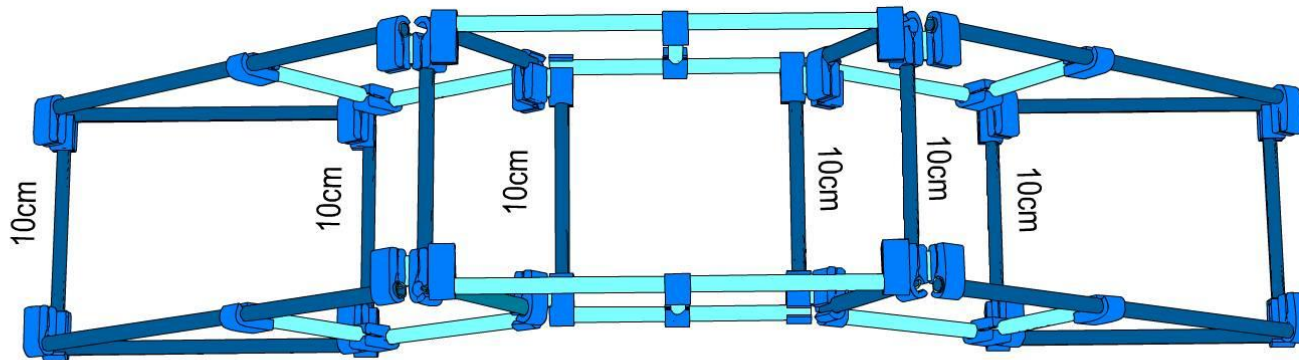
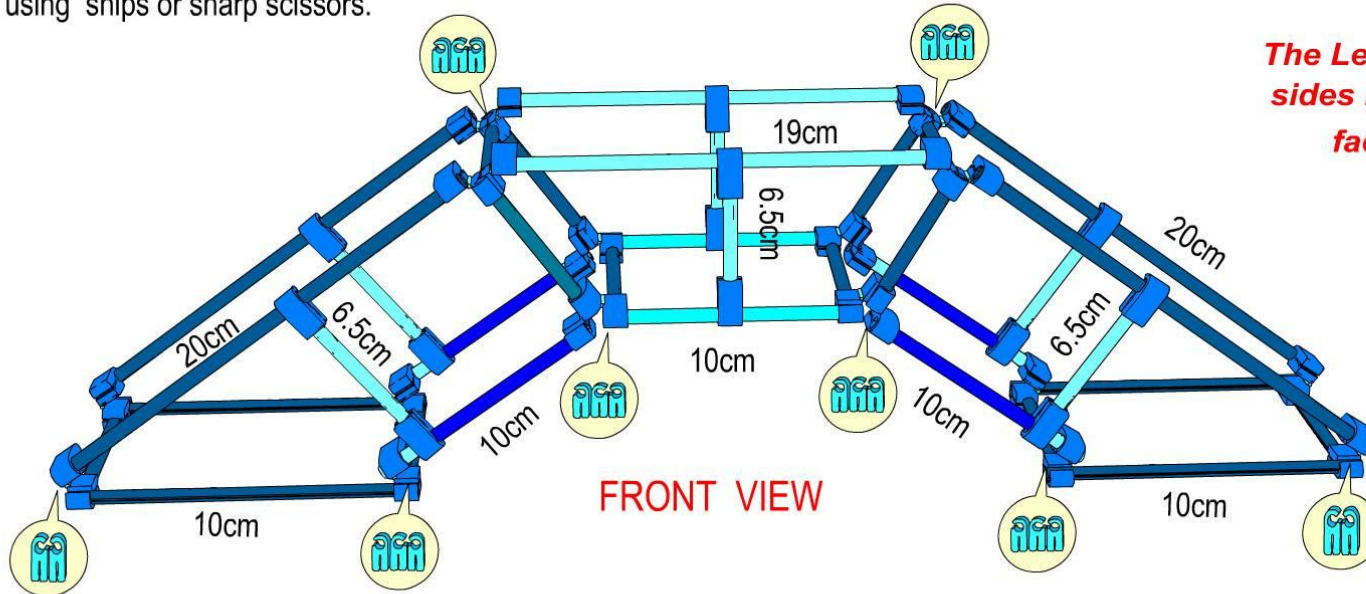

NOTE

The Left and Right Hand sides need the holes to face each other

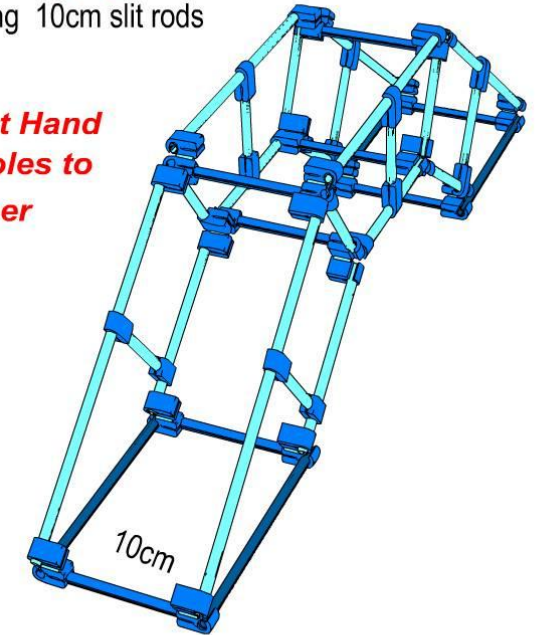

USING

Arch bridges are used for relatively short spans with the weight (eg road) on the top often with infill helping to keep it from moving.

Example shown below.

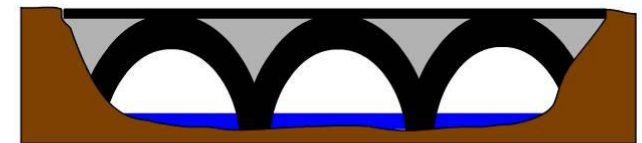

A 'three arched bridge' crossing a river

Kre8® Suspension Bridge - Working Drawing

Tip - Visit www.kre8.com for movies, zoomable pages and other support

Also see the 'Suspension Bridge Step-by-Step Animation

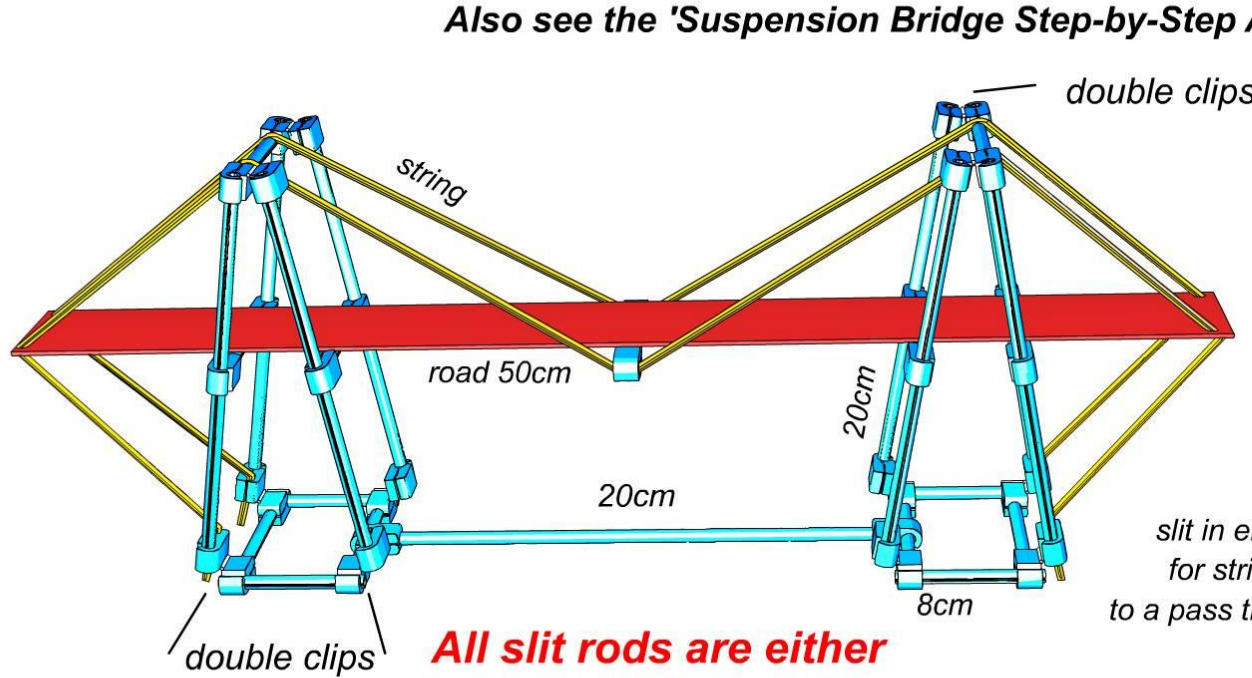

All slit rods are either 20cm or 8cm long

NOTE
The Left and Right Hand sides need the holes to face each other

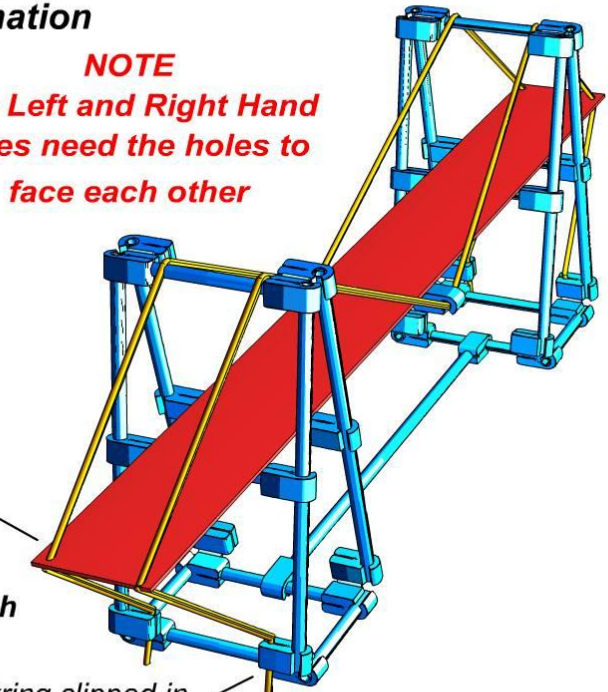

string clipped in the slot

To Assemble

- 1) Make FRONT of a tower.
 - 2) Make BACK of a tower.
 - 3) JOIN FRONT and BACK together.
 - 4) REPEAT and for second tower.
 - 5) LINK towers bases together with rod
 - 6) Add road strip on the 'tower road supports'
 - 7) Make the 'centre road support' for the string.
 - 8) Add SUSPENSION string as shown.
- String ends can be fixed in the connector slots.

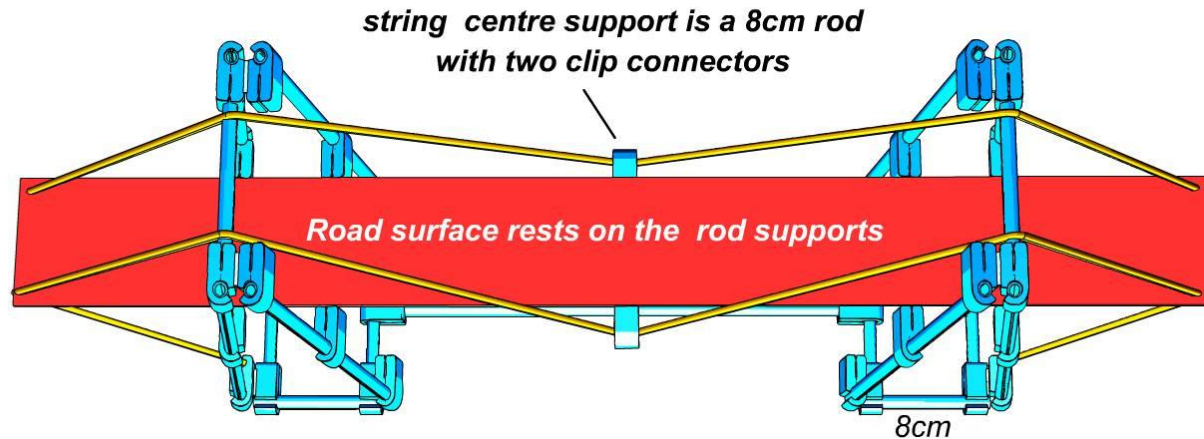

Suspension bridge is good for long bridges