

Contents

Introduction

Parts List

Making 1

Making 2

Top part

Jitter-fly top alternative

Activities

After assembling this model make it jitter about like a fly. Making consists of three main activities.

- 1) Making the body frame out of Kre8 connectors and tubes.
- 2) Making the weighted off-centre electric motor and power supply.
- 3) Adding the provided decoration on top or designing your own.

Key Words

Electric circuit, balance, off-centre, control, power, voltage, assembly using a kit.
Safety - hot glue gun

Design opportunities

Design and decorate as you wish instead of using the given top.

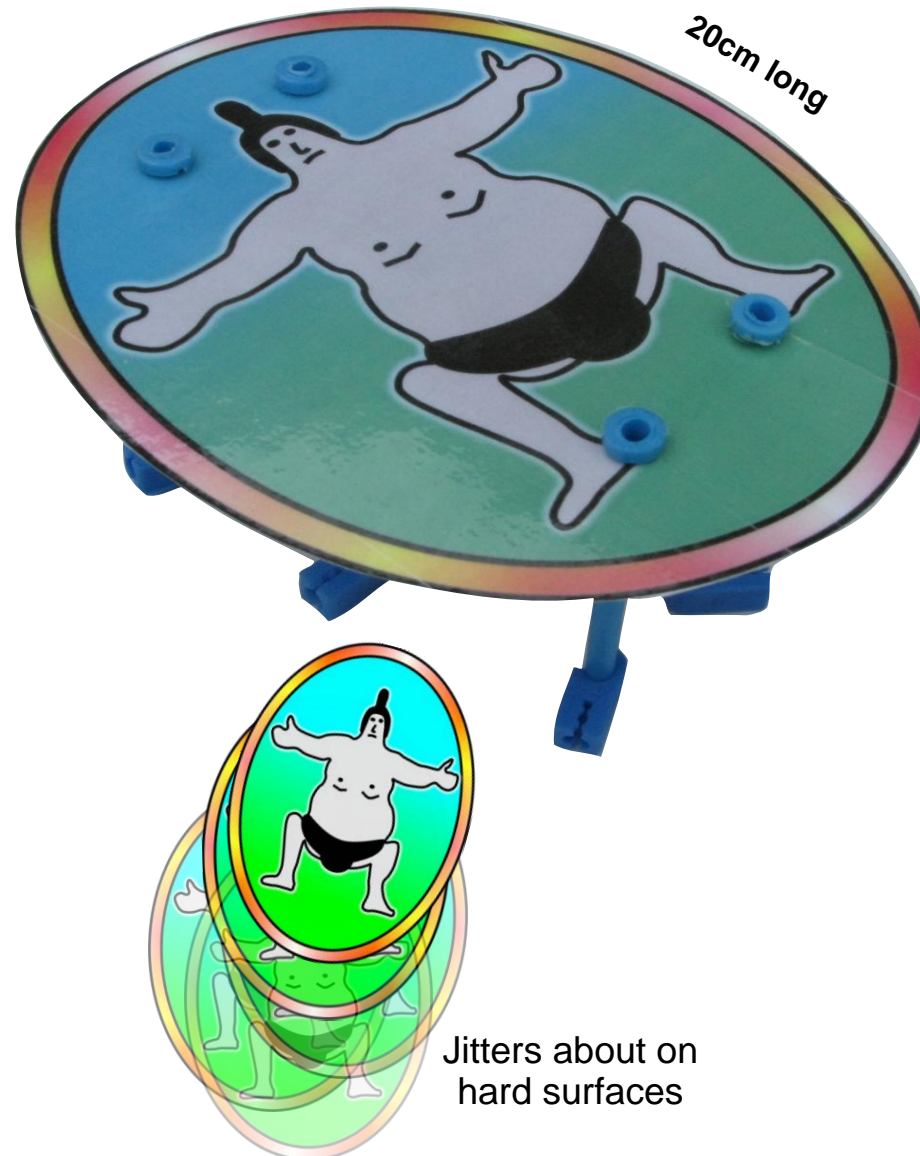

Educational Benefits

Making and understanding using a simple kit. Making a fun product that combines simple electrics (electric motor), mechanism (centrifugal force using off-set weight) and structures (frame and top decoration).

Personal - Sharing a practical experience together, quality outcome, testing, successful working outcome. Making a technical product. Co-operation and teamwork, able to follow instructions. role-play, problem solving, testing and evaluating. Possible links with biology and study of insects.

Extra challenges

- a) experiment with weight distribution to see if it can be steered,
- b) Make a different top design. (not the fixing holes are 30mm apart)

Tools and equipment needed
See next page called 'Parts'



1 x Red base 3 x 7 holes size



5 x Blue clip connectors

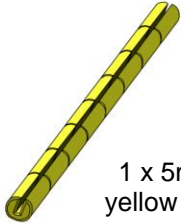

1 x 5mm dia yellow snap rod

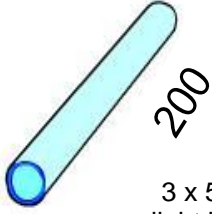

3 x 5mm dia light blue tube



1 x brass weight
(supplied inside a plastic holder which is removed by user)

Abrasive paper



1 x Small fast electric motor



1 x Pipe cleaner
(user cuts in half)

Tools

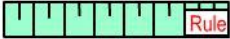

ruler



Screwdriver



Snips

Soldering

The motor wires can be soft soldered or the wires can be threaded and twisted instead.

Hot Glue Gun



Some parts need to be hot glued. Alternative methods of joining could be instead.

Hole punch

or cut out holes and then tape slit use reach the hole.



1 x 1.5V battery holder
[has space for one AA battery]



1 x resealable bag



4 x Blue collars

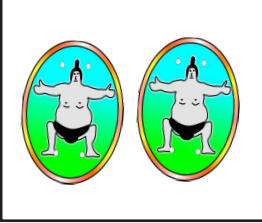

1 x laminated top (A4 Sheet)

Go to www.kre8.com for you free instructions (they can also be bought)

1 x paper insert

TO MAKE

Use these 'step-by-step instructions' as a guide and adapt as you want.

NOTES

- 1) Use metric ruler for measuring
- 2) For **EASY assembly** -
 - a) Smooth and **round the end of the rods** with abrasive paper then
 - b) **Push and twist** the rods into place.

1



Cut up the clip connectors using snips and then remove sharp edges

2

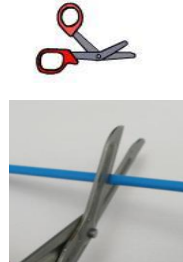

Cut up **four** light blues 75mm long and **two** 70mm long.

3a

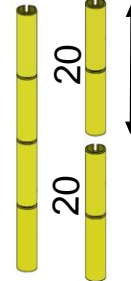

'Snap off' or cut off six 20mm long pieces.

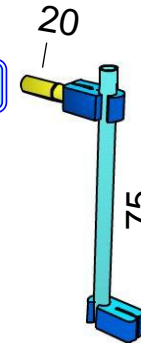

Assemble front legs as shown - using 75mm long tube.

3b

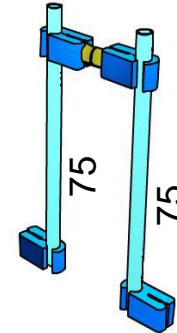

Assemble the second side then join together.

4

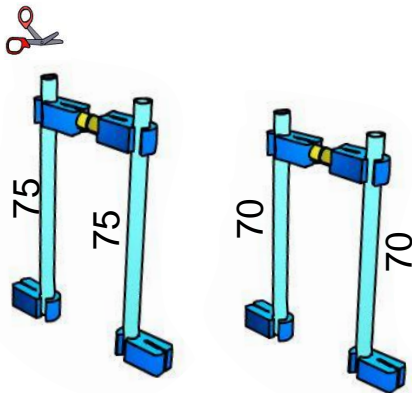

Make rear legs 75mm long (the same as the front legs) and a middle pair using 70mm long rods.

5

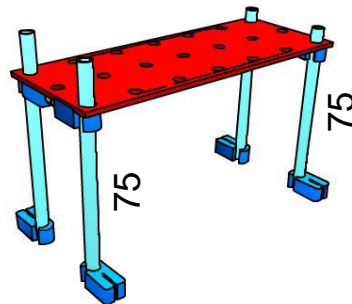

Start assembling front and back.

6

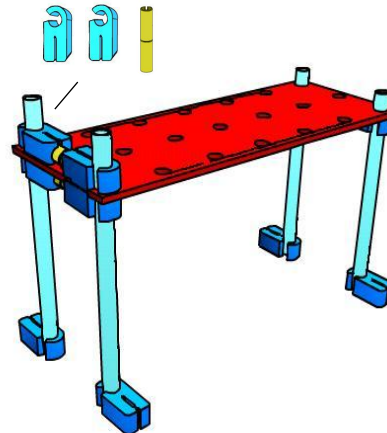

Add two clip connectors to top
Note - First join two clip connectors together with 20mm snap off piece

7

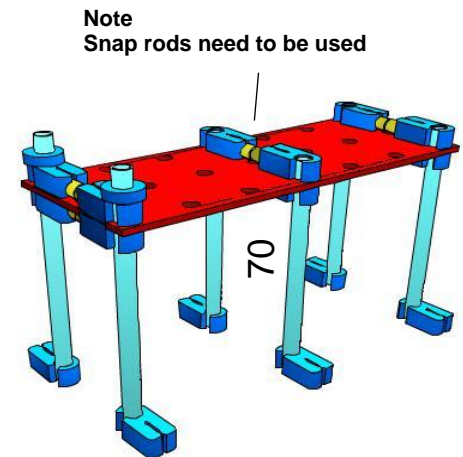

Complete legs as shown The shorter 70mm legs needs to be in the middle

8

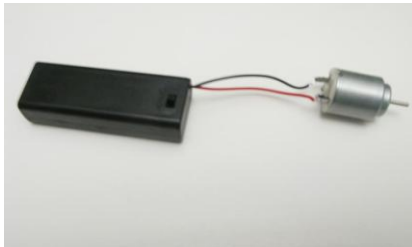

[Attach motor to battery holder . [Can put wires through hole and twist wires or soft solder.]

9



First get the brass weight by cutting off the extra plastic parts then

10



..... undo the two screws and push out the brass piece out as shown using screwdriver

11



Tightly add weight to motor as shown using screwdriver.

12



SAFETY
Only use glue gun under adult supervision

Hot glue the switch side of the battery holder. [or later you could use the rubber bands or tape to hold on]

13

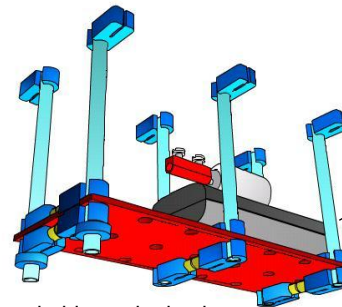

Hot glue the battery holder to the back of the frame - Turn over to do this .

14

Note
ONLY add glue on the front and back blue clip connectors

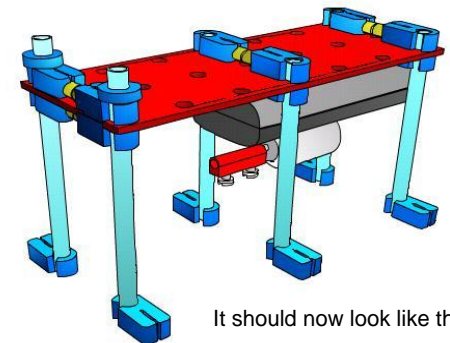

It should now look like this

15

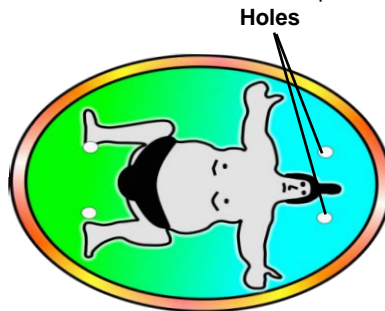

Cut out the top supplied then punch holes or cut (or out holes then seal any slit made with clear tape.) Note - two holes will do but four is better.

16



Hold the top on using the blue collars

17



Decorate as wanted - The pipe cleaners can be pushed down the tubes as shown. Add AA battery and test.

Kre8 kits supply this plastic laminated

Two variations for a sumo fight

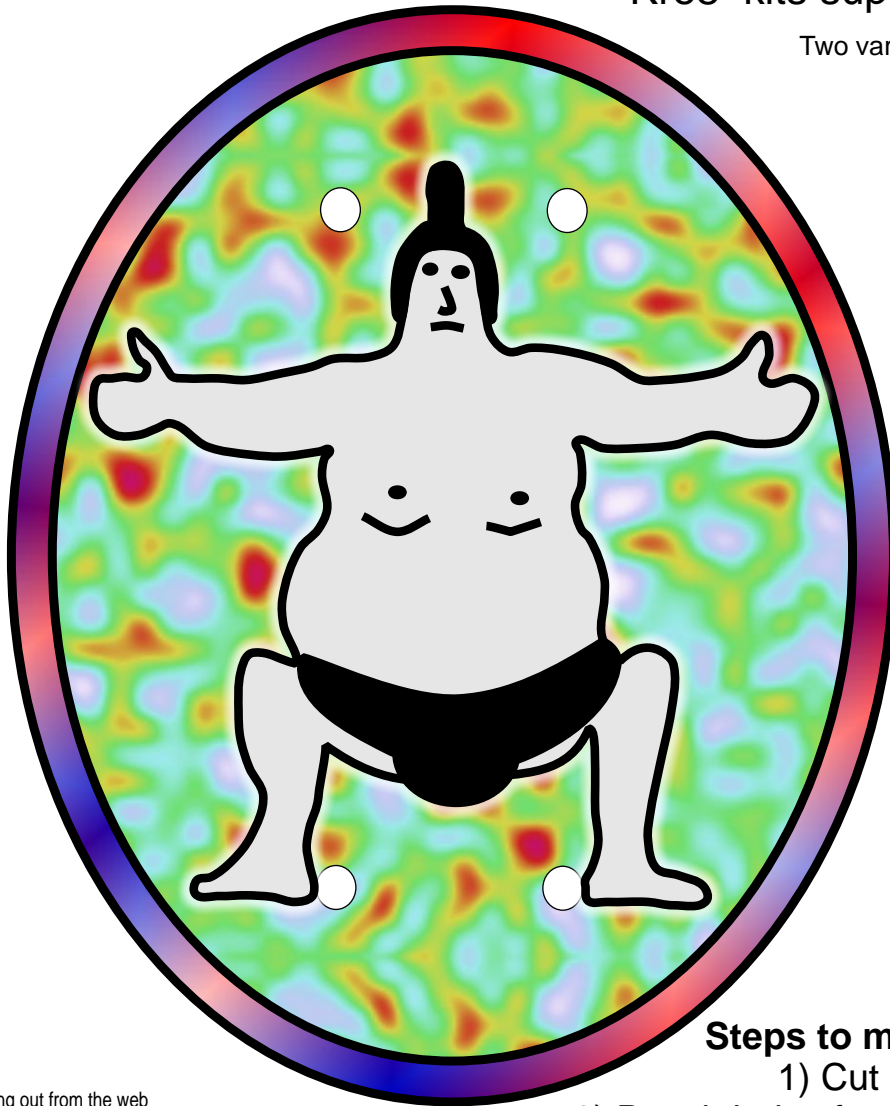

Steps to make ready to use

- 1) Cut out the shape
- 2) Punch holes for the fixing holes as marked
(using office paper punch)

Note
If printing out from the web
make sure you set your printer to A4 landscape

{Length of the fly shown needs to be about 20cm long}

Use this top instead

Steps to make ready to use

- 1) Cut out the shape
- 2) Laminate or add the piece of card
- 3) Punch holes for the fixing holes as marked
(using office paper punch)

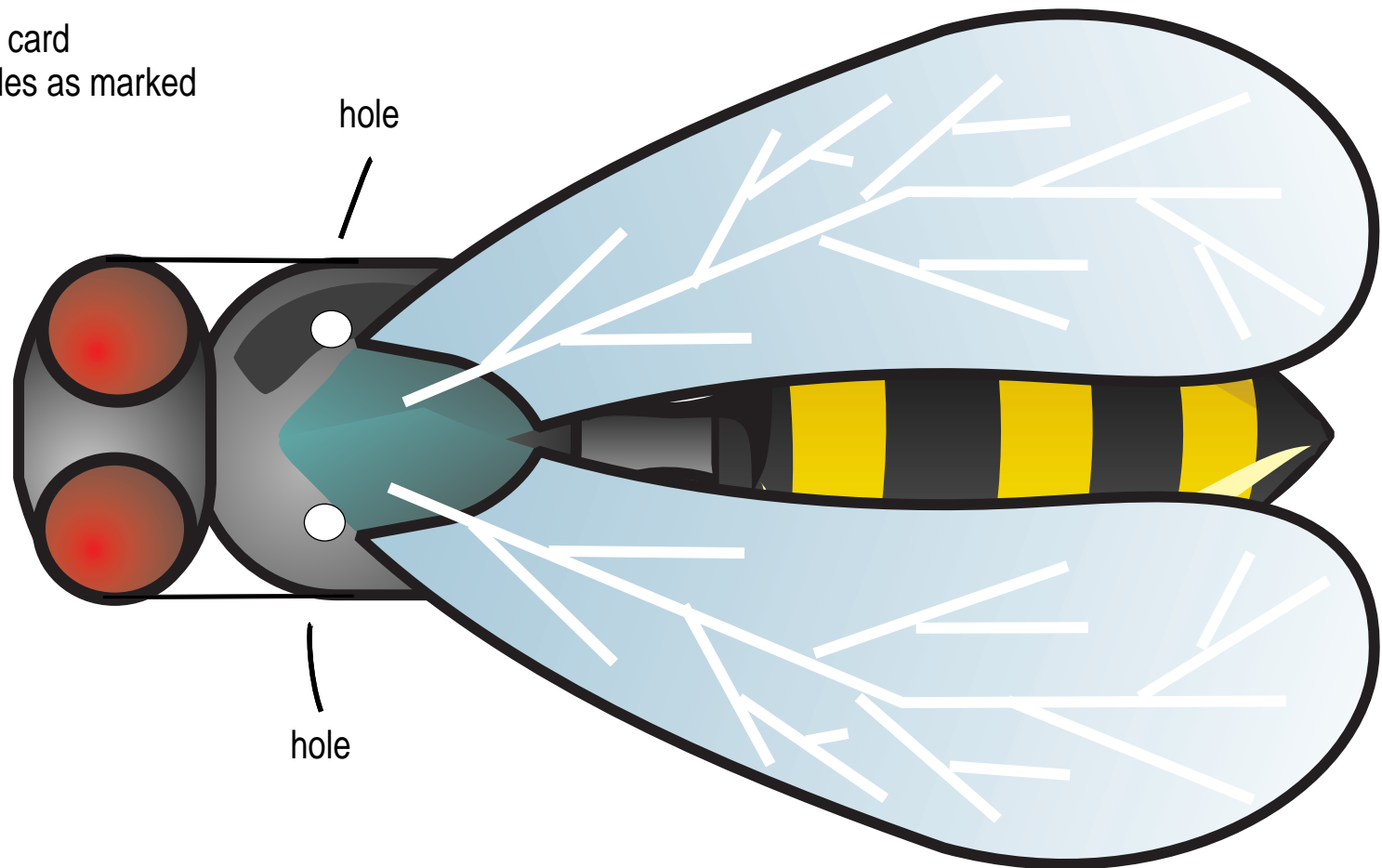

Make your own top

If you prefer to design your own top make sure the holes are 30mm apart.

Note

It printing out from the web
make sure you set your printer to A4 landscape
[Length of the fly shown needs to be about 20cm long]